

Moving  
Rehabilitation  
Forward™



# 3D ACTIVE TRAC®

## SERVICE MANUAL

Serial Numbers 1614 and above

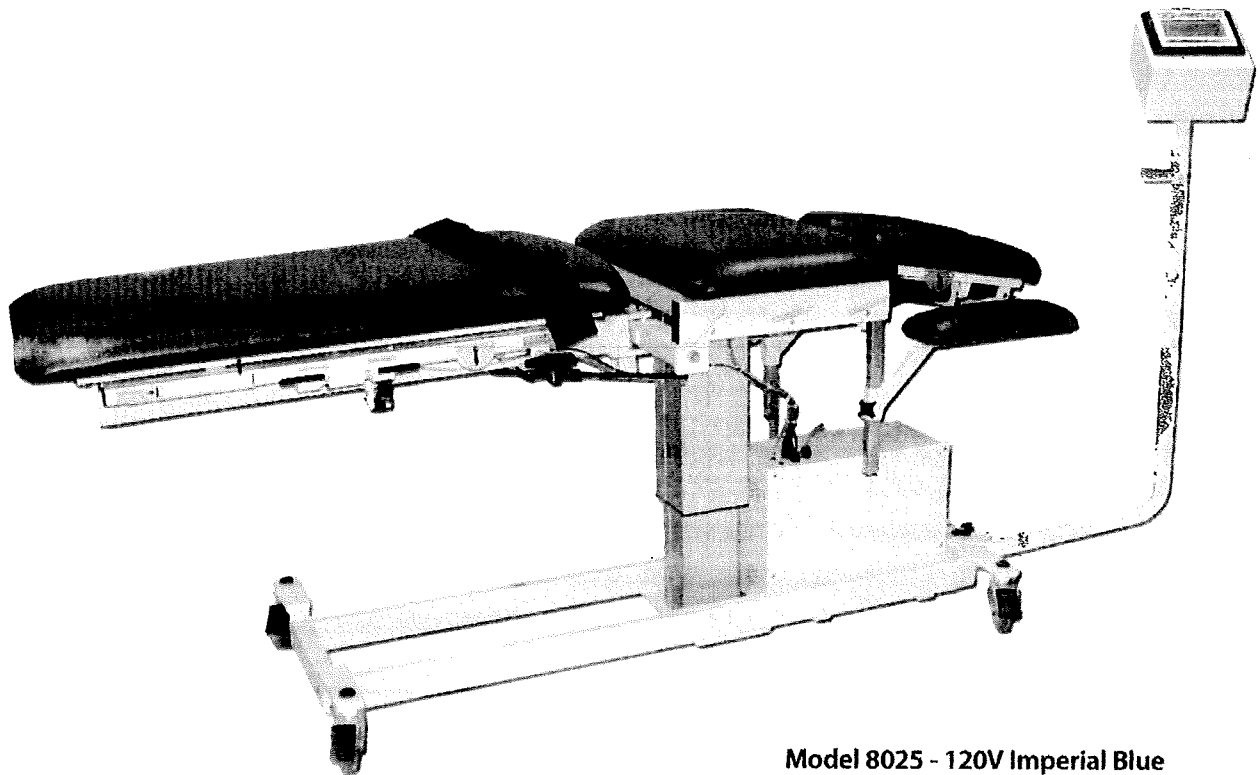

*426 lb Shipping Wt.  
82x29x29  
Crate*



ISO 13485 Certified

- Model 8025 - 120V Imperial Blue
- Model 8026 - 230V Imperial Blue
- Model 8036 - 120V Burgundy
- Model 8037 - 230V Burgundy
- Model 8038 - 120V Dove Gray
- Model 8039 - 230V Dove Gray
- Model 8040 - 120V Forest Green
- Model 8041 - 230V Forest Green
- Model 8042 - 120V Black
- Model 8043 - 230V Black
- Model 8045 - 120V Taupe
- Model 8046 - 230V Taupe

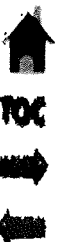

- **FOREWORD** ..... 1
- **1- THEORY OF OPERATION** ..... 2-8
  - ▶ 1.1 Overview ..... 2
  - ▶ 1.2 Hardware Overview ..... 2
  - ▶ 1.3 Software Overview ..... 8
- **2- SAFETY PRECAUTIONS** ..... 9-10
  - ▶ 2.1 Precautionary Definitions ..... 9
  - ▶ 2.2 Precautionary Instructions ..... 9
- **3- NOMENCLATURE** ..... 11
  - ▶ 3.1 3D ActiveTrac External Components ..... 11
  - ▶ 3.2 Table Adjustment Control ..... 11
- **4- SPECIFICATIONS** ..... 12-15
  - ▶ 4.1 Mechanical, Specification & Controls: Table, Belts & Cervical Traction Accessories ..... 12
  - ▶ 4.2 Electrical Specifications ..... 13
  - ▶ 4.3 Traction Application ..... 13
  - ▶ 4.4 Miscellaneous ..... 15
- **5- TROUBLESHOOTING** ..... 16-20
  - ▶ 5.1 Hi/Lo Flexion/Extension Motors ..... 16
  - ▶ 5.2 Problem Solving ..... 18
  - ▶ 5.3 Traction Failure ..... 20
  - ▶ 5.4 Specifications ..... 20
  - ▶ 5.5 Environmental Conditions ..... 20
- **6- REMOVAL AND REPLACEMENT** ..... 21-23
  - ▶ 6.1 Light Bulb Replacement ..... 21
  - ▶ 6.2 Caster Replacement ..... 21
  - ▶ 6.3 Foot/Lumbar Section Lock Adjustment ..... 21
  - ▶ 6.4 Meck-lok Replacement ..... 21
  - ▶ 6.5 Cable Replacement ..... 22
  - ▶ 6.6 Cable Adjustment ..... 22
  - ▶ 6.7 Com Box Replacement ..... 22
  - ▶ 6.8 Control Box Replacement ..... 23
  - ▶ 6.9 Column Motor Replacement ..... 23
  - ▶ 6.10 Lumbar Motor Replacement ..... 23
  - ▶ 6.11 Lumbar Air Cylinder Replacement ..... 23
  - ▶ 6.12 Cervical Unit Replacement ..... 24
  - ▶ 6.13 Bearing Replacement on Foot/Lumbar Section ..... 24
  - ▶ 6.14 Bearing Adjustment on Foot/Lumbar Section ..... 24
- **7- CALIBRATION** ..... 25-30
  - ▶ 7.1 Unit Calibration Overview ..... 25
  - ▶ 7.2 Removing Upholstery ..... 25
  - ▶ 7.3 Aligning the Table ..... 26
  - ▶ 7.4 Connecting the Force Gauge ..... 26
  - ▶ 7.5 Performing the Calibration ..... 27
  - ▶ 7.6 Replacing the Upholstery ..... 29
  - ▶ 7.7 Verifying Calibration Procedure ..... 30
- **8- MAINTENANCE** ..... 31
  - ▶ 8.1 General Maintenance ..... 31
  - ▶ 8.2 Cleaning ..... 31
- **9- PARTS** ..... 32-42
  - ▶ 9.1 Column to Base ..... 32
  - ▶ 9.2 Fixed to Frame ..... 33

- ▶ 9.3 Fixed Top to Column ..... 34
- ▶ 9.4 Head Section ..... 35
- ▶ 9.5 Under Frame Installations ..... 36
- ▶ 9.6 Tail Tube Installation ..... 37
- ▶ 9.7 Lower Lumbar Section ..... 38
- ▶ 9.8 Roller Frame ..... 39
- ▶ 9.9 Electronics Package ..... 40
- ▶ 9.10 Lumbar Gear Lock Upholstery- End Caps ..... 41
- ▶ 9.11 Upholstery & Touch Screen ..... 42
- **10- SCHEMATICS** ..... 43-83
  - ▶ 10.1 Panel Layout 3DAT Control Box ..... 43
  - ▶ 10.2 Box Control 3DAT Lower Right Side ..... 44
  - ▶ 10.3 Box Control 3DAT Lower Bottom ..... 45
  - ▶ 10.4 Box Control 3DAT Lower Top Side ..... 46
  - ▶ 10.5 Controller 3DAT MicroLogix ..... 47
  - ▶ 10.6 Controller 3DAT MicroLogix ..... 48
  - ▶ 10.7 Controller 3DAT MicroLogix ..... 49
  - ▶ 10.8 Controller 3DAT MicroLogix 230V ..... 50
  - ▶ 10.9 Controller 3DAT MicroLogix 230V ..... 51
  - ▶ 10.10 Controller 3DAT MicroLogix 230V ..... 52
  - ▶ 10.11 Relay 3DAT Control MCR, CR1 ..... 53
  - ▶ 10.12 Terminal Block One 3DAT ..... 54
  - ▶ 10.13 Terminal Block One 3DAT ..... 55
  - ▶ 10.14 Terminal Block One 3DAT ..... 56
  - ▶ 10.15 Terminal Block One 3DAT 230V ..... 57
  - ▶ 10.16 Terminal Block One 3DAT 230V ..... 58
  - ▶ 10.17 Terminal Block One 3DAT 230V ..... 59
  - ▶ 10.18 Terminal Block Two 3DAT ..... 60
  - ▶ 10.19 Terminal Block Two 3DAT 230V ..... 61
  - ▶ 10.20 Power Supply 3DAT 24VAC ..... 62
  - ▶ 10.21 Solinoid Valve 3DAT ..... 63
  - ▶ 10.22 Regulator Electronic 3DAT ..... 64
  - ▶ 10.23 Switch Pressure Plate ..... 65
  - ▶ 10.24 Fan 3DAT Cooling ..... 66
  - ▶ 10.25 Cable 3DAT Power ..... 67
  - ▶ 10.26 Cable 3DAT Power 230V ..... 68
  - ▶ 10.27 Switch 3DAT Proximity ..... 69
  - ▶ 10.28 Switch 3DAT Patient Control ..... 70
  - ▶ 10.29 Compressor Pump 3DAT 120V ..... 71
  - ▶ 10.30 Compressor Pump 3DAT 230V ..... 72
  - ▶ 10.31 Switch 3DAT Master ..... 73
  - ▶ 10.32 Switch 3DAT Master 230V ..... 74
  - ▶ 10.33 Terminal 3DAT Panel View ..... 75
  - ▶ 10.34 Terminal 3DAT Panel View ..... 76
  - ▶ 10.35 Terminal 3DAT Panel View ..... 77
  - ▶ 10.36 Transformer 3DAT 120 Toroid ..... 78
  - ▶ 10.37 Transformer 3DAT 230 Toroid ..... 79
  - ▶ 10.38 Filter Line 3DAT 230 ..... 80
  - ▶ 10.39 Diagram 3DAT Pneumatic ..... 81
  - ▶ 10.40 Schematic Wiring 3DAT ..... 82
  - ▶ 10.41 Schematic Wiring 3DAT 230V ..... 83
- **11- WARRANTY** ..... 84





Read, understand, and follow the Safety Precautions and all other information contained in this manual. This information is intended to be used by trained and certified Chattanooga Group technicians.

The specifications put forth in this manual were in effect at the time of publication. However, owing to Chattanooga Group's policy of continuous improvement, changes to these specifications may be made at any time without obligation on the part of Chattanooga Group.

Chattanooga Group requires all Field Technicians to stay informed and trained on all changes pertaining to the 3D ActiveTrac. As significant changes occur to the 3D ActiveTrac, service bulletins will be made available on our web site (chattgroup.com) in lieu of reprinted manuals.

Technicians repairing the 3D ActiveTrac agree to assume all risk and liability associated with this process.

**The 3D ActiveTrac is a prescription device to be used only under the supervision of and by the order of a physician or other licensed health care provider.**



TOC





## 1.1 OVERVIEW

This document is intended to help provide a technician with the knowledge necessary to effectively troubleshoot potential problems operating the 3D ActiveTrac. The 3D ActiveTrac control system consists of a variety of electrical and pneumatic components under the control of a programmable logic controller (PLC). While the operator will generally only be dealing with the touch screen, it is important to have a basic understanding of how all the components interact with one another. Individual components may be listed in more than one section of this document to help distinguish different characteristics of that component.

### A. PLC and Touch Screen

The principle components of the system are the PLC and the operator interface or touch screen. The touch screen accepts commands from the user and relays them through communication cable to the PLC. The PLC will evaluate the information and perform the appropriate response. Both of these devices have a program in them and all of the information processing is performed between the two.

### B. Electrical Components

While the PLC and touch screen are primary for processing information, a collection of electrical components must be used to carry out the required tasks. These components range in voltage from 120 volts AC to 24 VDC. There are also power-conditioning devices located on the incoming power line that aid in providing the unit with "clean" power. All of these devices must work in unison with the control of the PLC to perform the required tasks. A more detailed explanation of each device and how it functions is listed in the **Hardware Overview** Section below.

### C. Pneumatic Components

Ultimately, the goal of the 3D ActiveTrac control system is to provide the proper amount of force to the proper section of the table for the specified amount of time. While the time keeping is taken care of strictly in the PLC, several other components work together to make sure that the goal of providing the proper force to the proper section are achieved by manipulating and monitoring air pressure. While these components do operate off of electricity and are under the control of the PLC, their primary function is air management. An in-depth explanation of each device is also located in the **Hardware Overview** Section.

## 1.2 HARDWARE OVERVIEW

The hardware of the control system is comprised of all the electrical and pneumatic devices that are controlled by the PLC. The hardware in this system can be broken down into several categories, which include electrical devices, pneumatic devices, PLC operation, touch screen, and communications.

### A. Electrical Devices

All of the electrical devices in this system can be further broken down into classifications that assist in the understanding of the operation of the system. Some of the devices are classified as being in the power circuit and some are classified as being in the control circuit. In this case, the power circuit is comprised of any device that is operated with 120 volts AC or 230 volts AC. The control circuit consists of devices operated with 24 VDC.

#### 1. Power Circuit

Power is supplied to the control box via the hospital grade power cord supplied with the 3D ActiveTrac. One end of this cord plugs into the side of the control box and the other end plugs into any standard AC power receptacle.





## 1.2 HARDWARE OVERVIEW (CONTINUED)

### a. Power Switch/Fuse Holder

The power switch located on the side of the control box serves a couple different purposes. First, it is the point of connection for the power cord. Also, it contains both of the systems control fuses, the on-off switch and a line filter. The switch is used to either turn on or turn off power to the control box. There are two symbols located on the switch itself that indicate power-on or power-off. The power-on symbol on the switch is similar to a hyphen (-) and the power-off symbol resembles a circle (o). Located just above the switch is a door that opens to reveal a fuse holder. This red fuse holder can be removed from the switch and the fuses replaced. There are two fuses, one on the hot wire and one on the neutral wire. If either of these fuses are blown or missing, the 3D ActiveTrac will not operate and none of the components inside the control box will power up. Replacement fuses should be 3 Amps Type GMA. The power switch also has a built-in line filter. The line filter's only purpose is to help filter out excessive electrical noise. This helps in providing the system with cleaner power and also reduces any electromagnetic interference (EMI) that may radiate from the control box.

### b. Isolation Transformer

The isolation transformer is a medical grade toroidal transformer located in the bottom of the control box. It is a power conditioner for components inside the control box that run on AC and are connected to earth ground. It provides an isolated source of voltage and meets UL 2601-1 criteria for reducing leakage current from grounded components. Of the components that are powered with 120 volts AC, the two that are connected to this transformer are the PLC and the power supply, which converts 120 volts AC to 24 VDC. The components, which bypass the transformer, are the compressor and the table motor. The table motor provides up/down movement for the entire table and the foot/lumbar section of the table. If the table motor works properly, but the PLC or power supply won't power up, the transformer could be the potential problem.

### c. PLC (Programmable Logic Controller)

The PLC is located in the upper left hand corner of the control box. It is powered with 120 volts AC. There is a power-on indicator on the right side of the PLC. Other indicators or LEDs that indicate various statuses such as run mode, fault, and communications, are located vertical to the power-on LED. Any time the PLC has power and is ready to process information, the power and run LEDs should be on steady and the "Comm" LED should be flashing. If the "Comm" LED is not flashing, that would indicate either an open wire in the communication circuit or that the touch screen is not powered up. A flashing "Fault" LED would indicate a corrupt program and the user should try to cycle power to the control box. An explanation about how the PLC interfaces with the other electrical devices can be found in the **PLC Section on page 5.**

### d. Power Supply

The power supply is located in the upper middle section of the control box. The purpose of the power supply is to take 120 volts AC and convert it to 24 VDC. Most of the electrical components in the control box operate with 24 VDC. Like the PLC, it has a power-on indicator or LED, which should be illuminated if the power is on.

### e. Compressor

The air compressor is the primary pneumatic component but also falls under the power circuit because it runs on AC power. The compressor is not connected to ground and is physically isolated from the control box via rubber grommets located on each of the mounting studs; therefore, it is not required to be hooked to the isolation transformer. Power is supplied to the compressor through the contacts of a relay, which is controlled by the PLC. When the PLC applies voltage to the relay, a set of contacts close, switching AC power to the compressor, turning it on.





## 1.2 HARDWARE OVERVIEW (CONTINUED)

### f. Table Motor

The table motor is located above the control box and underneath the frame of the table. It is a stand-alone unit and does not interfere with any components inside the control box. It does, however, receive its power from the control box. It is medical grade and has inherent isolation; therefore, it does not have to be hooked to the isolation transformer. It is responsible for moving the entire table and the foot/lumbar section up and down. If the table works properly, but none of the table motor movements are working, then the motor has gone bad or there is an open wire in the circuit that supplies voltage to the motor.

## 2. Control Circuit

The control circuit consists of any device operating off 24 VDC. The principle component of the control circuit is the power supply. 24 VDC positive and 24 VDC common are both brought out of the power supply to a set of terminal blocks and from there it is either routed through the PLC or directly to the component.

### a. Cooling Fan

The cooling fan is located in the bottom of the control box between the transformer and the compressor. It is there to help move cooler air into the control box and keep components cool due to the amount of heat generated by the compressor. It only comes on when the table is performing a treatment. As soon as the treatment ends, the fan will switch off. The PLC is in control of turning the fan on and off and it is done through PLC output #9. There is a series of numbered LEDs across the bottom front of the PLC, which corresponds to the PLC output number. As long as the LED #9 in the bottom row of LEDs is lit, then the fan should be on.

### b. Table Lock Sensor

The table lock sensor is a proximity sensor, which is located underneath the foot/lumbar section of the 3D ActiveTrac. A proximity sensor is designed to activate when a metallic object gets within range of the sensing surface. In this case, the object is a metal bracket that will meet the face of the sensor when the operator turns the table lock to the unlocked position. It is 24 VDC powered and whenever the sensor senses the bracket, it will switch the same 24 volts back to the PLC (input #1). The corresponding LED should light up anytime the sensor senses that the table has been unlocked. The input LEDs are located on the bottom front of the PLC, just above the output LEDs.

### c. Control Relays

There are two control relays located inside the control box just behind the compressor and both of these relays are 24 VDC. The first relay is used to apply voltage to the compressor. The PLC outputs are intended to apply 24 VDC and the compressor runs on AC power. The PLC (output #6) will energize the relay and AC power will be switched to the compressor. Anytime that output LED #6 is illuminated, the compressor should be running. The compressor control relay will only be energized during a treatment.

### d. Patient Switch

The other relay is part of the patient switch circuit. Positive 24-VDC is connected through the patient switch. The voltage is connected to a normally closed set of contacts on the switch and then connected to the control relay. This relay will stay energized as long as the red button on the patient switch has not been pressed. Once the button has been pressed, the relay will de-energize until the button has been released. Once the button has been pressed, the relay will de-energize until the button has been released. The patient switch relay has two functions: First, it switches 24 VDC to the PLC (input #0). As long as the red button is not pushed, PLC input LED #0 should be lit. This serves as a signal to the PLC that everything is ok. It also provides the power to all of the PLC outputs. If the relay becomes de-energized due to pressing the red button on the patient switch, then all output power the PLC will be de-energized. This de-energizes all outputs from the PLC, which prevents any power from being provided to the output control devices.





## 1.2 HARDWARE OVERVIEW (CONTINUED)

### e. Touch Screen

The touch screen is powered from the control voltage. The only wires that are connected to the touch screen are in the communications cable (15-pin connector) that plugs into the control box next to the power switch. The control voltage of 24 VDC is incorporated into this cable for aesthetic reasons. If the touch screen will not power up, the problems could range from a faulty touch screen, a faulty power supply, or an open wire in the circuit that supplies voltage to the touch screen.

### f. Pneumatic (Electronic) Regulator

The pneumatic regulator is located in the upper right hand corner of the control box. It is powered with 24 VDC (output #8, on the PLC). The regulator is on all the time and the corresponding LED should be lit up as long as the control box is powered up and the patient switch has not been pressed. For a more detailed explanation on the functionality of this device and the other pneumatic devices, see the **Pneumatic Components Section on page 7.**

### g. Solenoid Valves

There are three solenoid valves, located in the center of the control box behind the fan. The valves are 24-VDC operated and are switched on and off through the control of the PLC. The solenoid on the bottom, or closest to the fan, is the lumbar valve. It is controlled by PLC output #5 and anytime that a lumbar treatment is being administered, the corresponding output LED should be lit. The valve directly above the lumbar valve is the cervical valve. It is controlled by PLC output #4 and during a cervical treatment output LED #4 should be illuminated. The lumbar or the cervical valve not actuating during the treatment cycle, indicates a faulty valve or connection. The last valve, located at the top of the row of valves, is the fill valve. It is operated by PLC output #7. This output should toggle intermittently on and off throughout the treatment cycle. When it is off, there should be a noticeable change in the sound of the compressor due to the fact that it is pumping air into the atmosphere and not the reservoir.

### h. Pressure Switch

The pressure switch is located in the middle right side of the control box. It has 24 VDC applied to one contact and anytime the air pressure applied to the switch exceeds the internal set point, the switch activates and switches the voltage to PLC input #3. The corresponding input LED should light anytime the switch has been made.

## B. PLC

The PLC is simply the central processing unit. Understanding how it processes information is not nearly as important as understanding how it interfaces with the components under its control. This section explains how the PLC sends and receives voltage to control the components that are connected to it.

**NOTE:** It is very important to understand that the PLC program does not change. If the 3D ActiveTrac is not functioning properly and the PLC is not in fault mode, the problem is in a specific device or the device's wiring.

### 1. Inputs

The PLC input terminal strip is located on the topside of the PLC. The way that the PLC interfaces with input devices is by simply receiving a voltage from them. In the 3D control system, the control voltage is 24 VDC and all of the input devices provide a positive DC signal to the respective input terminal. Any device that is electrical in nature requires two wires to operate. If the device is a standard AC receptacle in the wall, the two wires would be a hot and a neutral. In a 24- VDC circuit, the two wires are DC positive and DC common. In order for the PLC to recognize the positive voltage being applied to the input terminal a reference, or DC common, must be applied to the appropriate terminal on the input terminal strip, which is the "com" terminal. There are three input devices in the control system. They are the table lock sensor (#1), pressure switch (#3), and patient switch relay (#0). All three work in the same manner in that they switch the positive DC signal to an input when activated. The processor will recognize the signal using it in the program logic that resides in the PLC. All three also have a corresponding input LED on the PLC, which will illuminate when voltage has been applied to that input.





## 1.2 HARDWARE OVERVIEW (CONTINUED)

### 2. Outputs

The PLC output terminal strip is located on the bottom side of the PLC. The PLC interfaces with output devices by sending voltage for power-up. All the output devices in the 3D ActiveTrac control system are 24-VDC devices. In order for the device to work, it requires two wires, DC positive, which is provided by the PLC, and DC common, which is wired directly from the power supply to the device. A PLC output functions just like a normal relay. Positive 24-VDC is wired to a terminal and at that point, it is available for the PLC to use. If the program, which resides in the PLC, calls for an output device to be energized, an internal contact of the PLC will close and the positive DC voltage will be switched to the device. There are six output devices in the control system. They are: the cervical valve (#4), lumbar valve (#5), compressor relay (#6), fill valve (#7), pneumatic regulator (#8), and the cooling fan (#9). Each of these outputs has corresponding LED that illuminates if the PLC has turned that device on.

### 3. Analog

The analog module is located just to the right of the PLC. It is connected to the PLC through a ribbon cable. There is a green power indicator on the analog module. While PLC inputs and outputs work in an on or off fashion, an analog signal can be on, off, or anything in between. The module is used to interface with the pneumatic regulator. Data is processed inside the PLC and sent to the module through the ribbon cable. The module responds by sending a variable increasing or decreasing electrical signal to the pneumatic regulator. The regulator responds by either opening or closing in relation to the strength of the signal. This has the effect of either increasing or decreasing the amount of air pressure that is applied to the appropriate section of the 3D ActiveTrac. The regulator, in return, sends a signal back to the analog module proportional to the air pressure. That data is transferred to the PLC, which in turn processes the information and makes any necessary adjustments. This ensures that the correct amount of pressure is being applied during a given treatment.

## C. Touch Screen and Communications

The touch screen is the operator interface and it functions as if it were numerous input devices. Instead of switching voltage back to the PLC, it sends data through a communications cable (15-pin connector). The PLC in turn processes the data as it would any other input device. If at any time the touch screen loses communication to the PLC, an error message will indicate that the touch screen is offline and the touch screen will be inoperative. Communications must be established before the touch screen can serve any purpose.

### 1. Cables

Maintaining communication from the touch screen to the PLC requires a cable connection between communication ports. In the 3D ActiveTrac control system, the touch screen operating voltage is incorporated into the communications cable; therefore, one removable cable is connected to the control box. This means that instead of one communications cable, there are actually four. They are connected to each other at two sets of terminal blocks; one in the control box and the other in the touch screen box. DC voltage is incorporated into one cable inside the control box and branched out to the appropriate terminals of the touch screen inside the touch screen box.

### 2. Termination Points

There are essentially three termination points for the communication cables. First, a cable comes out of the PLC to a set of terminal blocks located between the analog module and the power supply. Each communication wire is connected to a separate terminal block at this point. Also connected to their own terminal block are DC positive and DC common, which power the touch screen. Connected to the other side of these terminals is the second communication cable. This cable has the DC voltage incorporated into it and is then mounted to the side of the control box where the touch screen cable will plug in. The touch screen plugs into the control box and is then broken out to a set of terminals mounted to the back of the touch screen itself. From there, the DC voltage is incorporated to the appropriate terminals and the communications plug is plugged into the touch screen communication port.







## 1.2 HARDWARE OVERVIEW (CONTINUED)

### D. Pneumatic Components

All of the pneumatic components were discussed in previous sections of this document in relation to location, operation voltage, and input or output numbers. Now it is important to discuss how these components interact to create and control airflow and pressure.

#### 1. Compressor

The compressor is responsible for providing the air pressure necessary to perform a treatment. It works in conjunction with the fill valve and the pressure switch to maintain at least 82 psi in the air reservoir.

#### 2. Lumbar Valve

The lumbar solenoid valve is a three port single acting solenoid. When this valve is de-energized, the input port will remain closed and air is not allowed to enter the valve. When the valve is energized, the input port opens and allows air to flow through the output port and on to the lumbar air cylinder. If the valve loses power or becomes de-energized again, any air that is trapped on the other side of the output port is released through the exhaust port. If a lumbar treatment is selected, it will remain energized to allow the free flow of air to the lumbar cylinder.

#### 3. Cervical Valve

The cervical solenoid valve is a three port single acting solenoid. When this valve is de-energized, the input port will remain closed and air is not allowed to enter the valve. When the valve is energized, the input port opens and allows air to flow through the output port and on to the cervical air cylinder. If the valve loses power or becomes de-energized again, any air that is trapped on the other side of the output port is released through the exhaust port. If a cervical treatment is selected, it will remain energized to allow the free flow of air to the cervical cylinder.

#### 4. Fill Valve

The valve's primary purpose is to work with the compressor and pressure switch in maintaining a constant pressure supply. The fill valve is plumbed different than the lumbar and cervical valve to achieve the desired goal. When the fill valve is de-energized, air flows out of the compressor, through the input port and out of the exhaust port. In this state, the compressor is just pumping air into the atmosphere and in an idle state. When the fill valve becomes energized, the exhaust port closes and air is allowed through the fill valve and into the reservoir. A distinct difference in the compressor noise is noticed when the fill valve is filling the reservoir.

#### 5. Pressure Switch

The pressure switch is plumbed directly into the reservoir. If the air pressure in the reservoir falls below approximately 80 psi, the pressure switch will lose its input to the PLC, which will energize the fill valve. Once the compressor has replenished the reservoir to about 82 psi, the pressure switch will be activated, sending its input to the PLC, which will de-energize the fill valve. There is a short time delay between the time the pressure switch gives the input and the time that the PLC will turn off the fill valve (approximately five seconds). This allows the reservoir pressure to be raised above the pressure switch threshold of 82 psi.

#### 6. Pneumatic (Electronic) Regulator

The pneumatic regulator works in conjunction with the analog module to maintain the appropriate pressure on the lumbar and cervical air cylinders. The valve receives a variable electrical signal from the analog module and gradually opens an internal orifice accordingly. It also has the ability to send a variable signal to the analog module that is proportional to the air pressure. This allows the PLC to make any necessary adjustments. During any type of ramp down phase, air is released through the exhaust port of the regulator and not the exhaust ports of the lumbar or cervical cylinders. This also has the effect of allowing the regulator to monitor the air at all times.





## 1.2 HARDWARE OVERVIEW (CONTINUED)

### 7. Lumbar and Cervical Cylinders

The lumbar cylinder is located underneath the foot/lumbar section of the 3D ActiveTrac. As air is pumped into the cylinder, it extends and applies a gradual force to the patient being treated. The cervical cylinder is located underneath the headpiece of the cervical section. It is a smaller cylinder and the amount of force that is applied to this cylinder is much lower than that of the lumbar cylinder. The cervical cylinder is also fitted with a safety pop-off valve that will open up and release air to the atmosphere if the pressure in the cylinder exceeds 55 pounds (+/- 10%).

## 1.3 SOFTWARE OVERVIEW

Both the PLC and touch screen have programs in them that continuously run anytime power is applied. The programming software for the PLC is Allen-Bradley RSLogix 500 and the software for the touch screen is Allen-Bradley Panelbuilder32. Both of these programs are stored in a central processing unit and as long as communications have been established and the PLC has not faulted, the programs will be in working order.





## 2.1 PRECAUTIONARY DEFINITIONS

The precautionary instructions found in this section and throughout this manual are indicated by specific symbols. Understand these symbols and their definitions before operating this equipment. The definition of these symbols are as follows:

### CAUTION

#### Caution

Text with a "CAUTION" indicator will explain possible safety infractions that could have the potential to cause minor to moderate injury or damage to equipment.

### WARNING

#### Warning

Text with a "WARNING" indicator will explain possible safety infractions that will potentially cause serious injury and equipment damage.

### DANGER

#### Danger

Text with a "DANGER" indicator will explain possible safety infractions that are imminently hazardous situations that would result in death or serious injury.



#### Explosion Hazard

Text with an "Explosion Hazard" indicator will explain possible safety infractions if this equipment is used in the presence of flammable anesthetics.

#### NOTE

Throughout this manual, "NOTE" may be found. These Notes are helpful information to aid in the particular area or function being described.

## 2.2 PRECAUTIONARY INSTRUCTIONS

### CAUTION

- Read, understand, and practice the precautionary and operating instructions found in this manual. Know the limitations and hazards associated with your treatment table. Observe any and all precautionary and operational decals placed on the table.
- DO NOT operate this table in an environment where other devices are being used that intentionally radiate electromagnetic energy in an unshielded manner. Portable and mobile RF communications equipment can affect Medical Electrical Equipment.
- This table generates, uses, and can radiate radio frequency energy and, if not installed and used in accordance with the instructions, may cause harmful interference to other devices in the vicinity. However, there is no guarantee that interference will not occur in a particular installation. Harmful interference to other devices can be determined by turning this table on and off. Try to correct the interference using one or more of the following: reorient or relocate the receiving device, increase the separation between the equipment, connect the table to an outlet on a different circuit from that which the other device(s) are connected, and consult the Chattanooga Group Service Department for help.
- This table should be operated in temperatures between 59° F (15° C) and 95° F (35° C), with relative humidity ranging from 20% - 75%.
- This table should be stored and transported in temperatures between -29° F (-34° C) and 149° F (65° C), with relative humidity ranging from 15% - 95%.
- Do not exceed table weight capacity of 300 pounds (136 kilograms).
- Support the table section(s) when making any adjustments.
- Always monitor the patient closely during treatment.
- A licensed practitioner experienced with traction therapy must be familiar with all instructions contained in this manual before administering traction therapy.
- When replacing the Com Box, pull on end piece of plug only. Do not pull on cable.
- When removing the Control Box, be certain not to loosen any other fasteners on the bottom of the control box by mistake.





## 2.2 PRECAUTIONARY INSTRUCTIONS (CONTINUED)

### **WARNING**

- Federal law restricts this table to sale by, or on the order of, a licensed practitioner.
- Make certain that the table is electrically grounded by connecting only to a grounded electrical service receptacle conforming to the applicable national and local electrical codes.
- The 3D ActiveTrac should not be used adjacent to or stacked with other equipment, and if adjacent or stacked use is necessary, the 3D ActiveTrac should be observed to verify normal operation in the configuration in which it will be used.
- The table should be left in its lowest position when unattended in order to reduce injury due to falls while getting on and off the table.
- Never place your hands and feet near the working mechanism of the table when making any and all adjustments to height or table sections. Moving parts could cause pinch points.
- When making adjustments to the table sections, make certain the patient weight is supported before adjusting.
- Staff should assist patients when they are getting on or off the treatment table to avoid falls.
- Never transport a patient on the 3D ActiveTrac. The table is not designed to support a patient during transport.
- Do not allow any unsupervised patient access to the traction table.
- The caster wheels should be locked before the loading or unloading of a patient. Do not reposition or allow the patient to get on or off the table while the table is ascending or descending.
- This table should only be operated under the prescription and supervision of a licensed medical practitioner that is familiar with the precautionary measures and operational functions associated with the table being used.
- Should the 3D ActiveTrac Mains Power Cord become frayed or damaged, immediately stop use of the table and contact Chattanooga Group at 1-800-266-0026 for service.
- Use only the appropriate or listed fusing. Failure to use the stated fuses may result in equipment damage and/or personal injury.
- Disconnect power from the unit prior to servicing. Reconnect power to the unit to verify function after servicing.

### **DANGER**



- Do not allow any person, object, or device to be under the table while the table is in operation.
- Possible explosion hazard if used in the presence of flammable anesthetics.



TOC





## 3.1 3D ACTIVETRAC EXTERNAL COMPONENTS

The nomenclature graphics below, Figure 3.1, indicate the general locations of the major external components of the 3D ActiveTrac.

Know the components and their functions before performing any operation of or service to the 3D ActiveTrac.

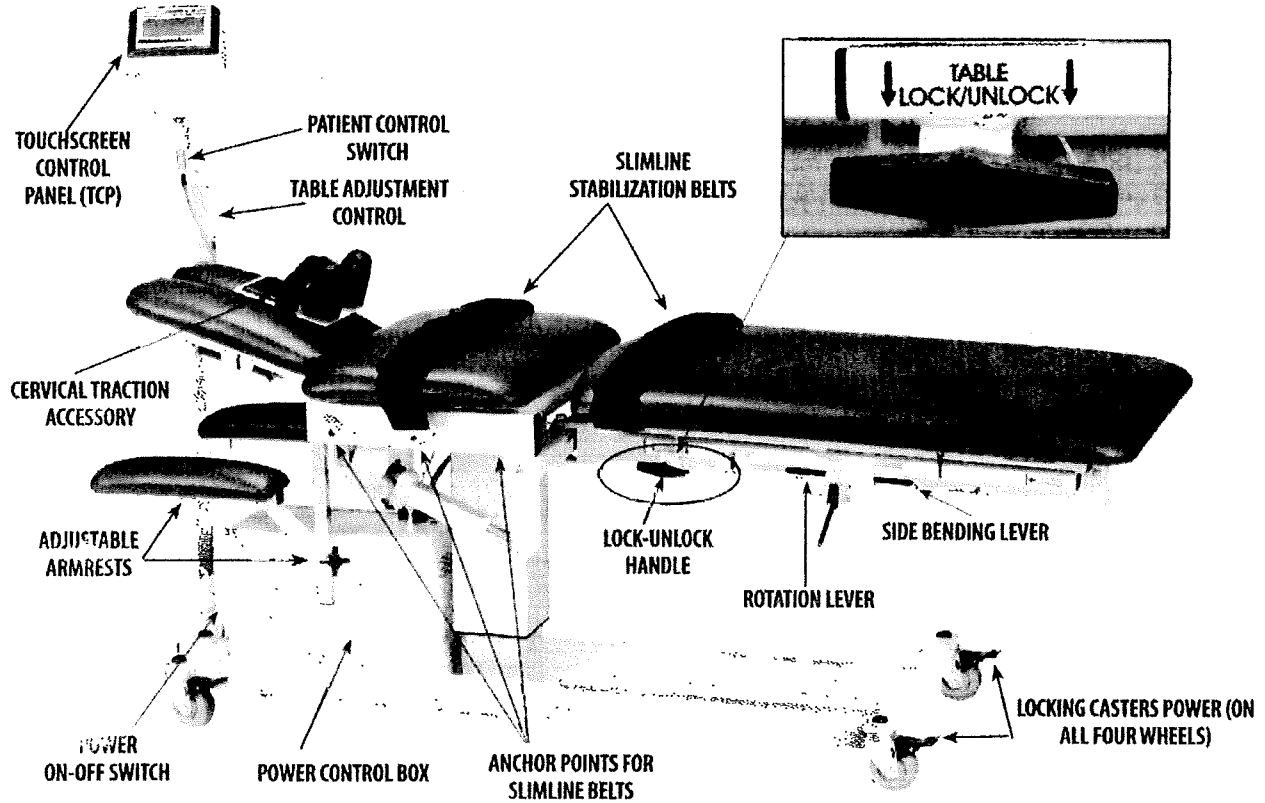

FIGURE 3.1

## 3.2 TABLE ADJUSTMENT CONTROL

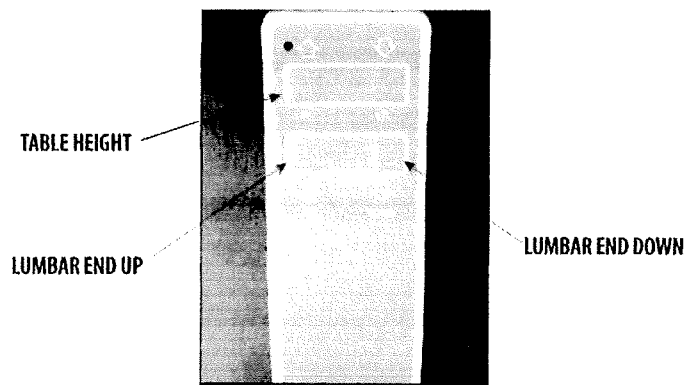

FIGURE 3.2





## 4.1 MECHANICAL SPECIFICATIONS AND CONTROLS: TABLE, BELTS AND CERVICAL TRACTION ACCESSORY

### A. Table

1. Unit dimensions are 25" wide x 23" to 35" (table surface) high x 78" long. The touchscreen control extends 15" above table surface. The operational footprint is as follows: When the foot/lumbar section is extended (six inches) and allowing for the extra length for the touchscreen (nine inches), the total length is 93". Operational width, allowing for side bending (13" each side for a total of 26"), is 54".
2. Lower table section opens 6 inches (+/- .5).
3. Lower table section equipped with lock so table doesn't slip during patient set up.
4. Lower table section will move upward 25 degrees and downward 20 degrees (+/- 5 degrees).
5. Lower table section will side bend 15 degrees either direction from neutral (+/- 5 degrees).
6. Lower table section will rotate 15 degrees either direction from neutral (+/- 5 degrees).
7. Table side bending and rotation controlled manually with positive-lock mechanism.
8. Table side-bending and rotation controls mounted on both sides of lumbar section of the table—accessible from either side.
9. Upper face slot/head rest section will move upward 30 degrees (+/- 5 degrees) and downward 20 degrees (+/- 5 degrees).
10. Upper face slot/ head rest section controlled manually with positive lock mechanism.
11. Electric high-low from 23 to 35 inches table height (+/- .5).
12. All surfaces that come in contact with patient's skin are easily cleaned.
13. All surfaces that come in contact with patient's skin are made of non-toxic and non-reactive materials so that they are appropriate to be in contact with skin for up to 60 minutes, 5 times per week for 8 weeks (this dosage chosen because it far exceeds normal dosage, to err on side of safety).
14. Table equipped with caster wheels—the two on the head end are lockable.
15. Table capacity is 300 pounds (136 kilograms).

### B. Belts

1. Thoracic and pelvic belts, when closed and attached to table (simulating a treatment session), will withstand at least 300 pounds (+/- 10) longitudinal tension.
2. Thoracic and pelvic belts, when properly set up on patient's skin, will not slip when force of 200 pounds is applied (+/- 10).
3. Table equipped with metal loops on either side of the upper and lower ends of the table, near the split, for attachment of slimline belts for patient stabilization.

### C. Cervical Traction Accessory

1. The cervical traction accessory adjusts infinitely upward to 30 degrees and downward 20 degrees (+/- 5).
2. Traction will not start and user is warned if user attempts to start cervical traction with table unlocked.

### D. Touch Screen Display (TCP)

1. The TCP box will be mounted on a support bar at a 30 degree angle (+/- 5).
2. The TCP box will swivel through a 170 degree arc (+/- 5) and lock into position by tightening a winged knob.
3. Touch screen control box mounts on the front end of the lower frame.

### E. Hand Held Control

1. Electric high-low and table flexion/extension controlled with a hand held control.
2. Hand held control switch contains an "up" arrow over the left side button and a "down" arrow over the right side button, with the words "Hi/Lo" under the top row of buttons and the words, "Flex/Ext" under the second row of buttons.





## 4.1 MECHANICAL SPECIFICATIONS AND CONTROLS: TABLE, BELTS AND CERVICAL TRACTION ACCESSORY (CONTINUED)

### F. Other Accessories

1. Flexion stool accessory adjusts in height from 12 to 18 inches (+/- 5).
2. Slimline belts are 69" long with sacral positioning pad to secure point during mobilization treatment.
3. An optional foot control is available.

## 4.2 ELECTRICAL SPECIFICATIONS AND STANDARD REQUIREMENTS

### A. Electrical Specifications

1. EN60601-1 electrical equipment classification - Class I equipment
2. Degree of protection against electrical shock - Type B applied part
3. Electrical Ratings: USA - 120VAC, 60 Hz, 5 AMP; Europe: 230 VAC, 50 Hz, 3.0 AMP
4. Fuse Rating: USA: 125V, T5AL; Europe - 250V, T3AL
5. Environmental Conditions: Normal operating range is between 59° F (15° C) and 95° F (35° C), 20% to 75% RH; Conditions for storage and transport: -29° F (-34° C) and 149° F (65° C), 15% to 95% RH
6. A power box mounted on the table frame below the table surface will contain power-on/off switch for traction.
7. Unit has a patient control switch that when pressed, discontinues traction force.
8. Hand held controls for table hi/low and flex/ext work when the unit is plugged into wall outlet.
9. The motors are equipped with a thermal cutout that protects them from over-heating.

### B. Electrical Standards Requirements

- Table passes EN-60601-1 safety testing and EN60601-1-2 electromagnetic compatibility.

## 4.3 TRACTION APPLICATION

### A. User Defined Control

1. User defines all treatment parameters on a Touchscreen Control Panel (TCP).
2. TCP features icons that, when pressed, select a treatment parameter.
3. Treatment is controlled by a programmable logic controller (PLC) that is not programmable by user.
4. User initially chooses either cervical or lumbar mode.
5. All lumbar and cervical mode parameters are identical except for maximum force allowed.
6. Lumbar traction force = 10-200 pounds (4.5-90.7 kilograms).
7. Cervical traction force = 10-50 pounds (4.5-22.7 kilograms).
8. User can choose display in either kilograms or pounds—default is whatever was chosen in last treatment session.
9. User can choose either static or intermittent treatment modes--default is whatever was chosen in last treatment session.
10. User can choose a ramp up and a ramp down time (time it takes to reach max force and relax force at end of treatment, respectively)—choices are 30 seconds, 1, 2 and 3 minutes—default is whatever was chosen in last treatment session.
11. User chooses treatment time--default is 1 minute (lowest possible).
12. User chooses treatment force--default is 10 pounds (lowest possible).  
Only during ramp up phase, the increase in force will be evenly distributed over the entire ramp time, in one-second intervals. For example, if the user selects a force of 60 pounds (in a subsequent screen) and a ramp up time of one minute, the force will increase one pound per second for 60 seconds. If the user selects 60 pounds with a ramp up time of two minutes, the force will increase ½ pound every second for 120 seconds.





## 4.3 TRACTION APPLICATION (CONTINUED)

14. Only during ramp down phase, the decrease in force will be evenly distributed over the entire ramp time, in one-second intervals. For example, if the user selects a force of 60 pounds (in a subsequent screen) and a ramp down time of one minute, the force will decrease one pound per second for 60 seconds. If the user selects 60 pounds with a ramp down time of two minutes, the force will decrease ½ pound every second for 120 seconds.
15. During runtime, intermittent mode, the hold time and rest time begin counting down after the set point for the force is reached.
16. Total treatment time includes hold and rest phases and the transition time (preprogrammed) between hold and rest phases. **(See Table 1).**
17. Total treatment time does not include ramp up and ramp down.
18. During treatment, when force changes, the rate at which force changes is preprogrammed **(see Table 1)**. This rule applies in the following circumstances: When transitioning from hold to rest force; rest to hold force; or when stopping treatment due to power off or pressing STOP.
19. This rule does not apply during ramp up and ramp down phases.
20. **NOTE:** When the patient control switch is pressed, the ramp down time is faster than indicated in **Table 1**.

Force Range (pounds)	Ramp up Time (sec.)	Ramp Down Time (sec.)
10 to 17	5	5
18 to 25	6	6
26 to 33	7	8
34 to 41	8	10
42 to 49	9	12
50 to 74	10	14
75 to 99	15	19
100 to 134	20	24
135 to 169	25	30
170 to 200	30	36

21. After the user presses start, the TCP will display treatment maximum force entered and actual force runtime (numerically and graphically). Actual force will be displayed only in graphic form. Total treatment time will count down. Timing phase (ramp up, ramp down, hold phase or rest phase) is displayed, and time for the phase will count down. If in static mode, the display will read, "hold phase" for entire treatment time, excluding ramp up and ramp down.
22. All runtime displays will be accurate (within spec) and reflect what the user entered during set up screens. This includes treatment time countdown, treatment phase displayed and its countdown, and current force.
23. During runtime, force displayed is +/- 3 pounds of actual when measured by calibrated reference.
24. During runtime, pop-off valve will release if pressure in cylinder exceeds 55 pounds (+/- 10%).
25. During runtime, time displayed is correct when compared to calibrated time reference.
26. PAUSE will hold the current treatment parameters static and revert the TCP display to the Time/Force set screen.
27. After pausing, user can re-enter any treatment parameters on the Time/Force set screen only. (The back button is not operational on the Time/Force set screen while in Pause mode).
28. After pausing, pressing Start on the treatment time/force entry screen resumes treatment where it left off, unless parameters were changed.







### 4.3 TRACTION APPLICATION (CONTINUED)

29. After pausing and resuming, if time parameter was changed, time countdown will display new time.
30. After pausing and resuming, if force parameter was changed, new force will be attained at a preprogrammed rate (**see Table 1 on page 14**). On the runtime screen, pressing STOP will discontinue force and return the TCP display to the Welcome Screen.
31. During treatment, pressing the patient control switch will discontinue force and return the TCP display to the Welcome Screen.
32. At the end of treatment (when time counts down to 0), force discontinues and TCP display returns to Welcome Screen.

#### B. Intermittent Mode

1. In intermittent mode, user sets rest force as a percentage of maximum force. Choices are 0, 25, 50, and 75% - default is whatever was chosen in last treatment session.
2. In intermittent mode, user sets hold and rest times. The range is 15 seconds to 5 minutes, 55 seconds, in 5- second increments. Default is whatever was chosen in last treatment session.
3. The rate of force change up or down during intermittent mode is preprogrammed at a deliberate rate based on the amount of force change following **Table 1 on page 14**.

### 4.4 MISCELLANEOUS

#### A. User Guide

- A user guide will be supplied with each unit outlining installation, setup, and indications for use, precautions, contraindications, unit specifications and general product use.

#### B. Labeling

- All labeling will conform to the standards listed above and internal Chattanooga Group label controls.





## 5.1 HI/LO OR FLEXION/EXTENSION MOTORS

### **WARNING**

- Use only the appropriate or listed fusing. Failure to use the stated fuses may result in equipment damage and/or personal injury.

### **WARNING**

- Disconnect power from the unit prior to servicing.
- Test the unit to verify function after servicing before treating a patient.

If the Hi/Lo or Flexion/Extension motors don't work, make sure the motor is receiving power:

- Check the plug to make sure it is securely plugged into a specified electrical wall outlet.
- Check the plug to make sure it is securely plugged into the receptacle at the front of the Power Control Box.
- If the table is plugged in, check building circuit breaker to make sure wall outlet is receiving electricity.
- Thermal cutout may have activated. Allow the motor to cool.
- The 5 amp control box fuse may have blown.

**ONLY QUALIFIED SERVICE PERSONNEL** should replace as follows:

- Shut off power to the Power Control Box.
- Remove the Power Cord from the wall outlet.
- Remove the Power Cord from the Power Control Box.
- Using a small, flat screwdriver, lightly pry open the fuse holder cover. The cover will drop down (**Figure 5.1**).
- Using the screwdriver, lightly pry open the fuse holder (**Figure 5.2**).
- Gently pull out the fuse holder (**Figure 5.3**).

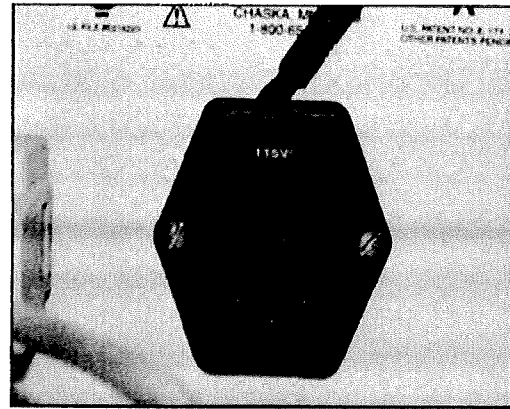

Figure 5.1

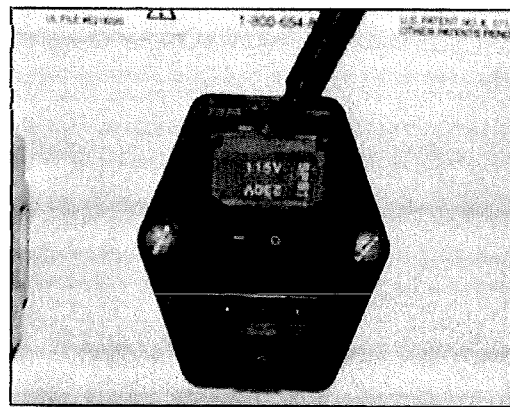

Figure 5.2

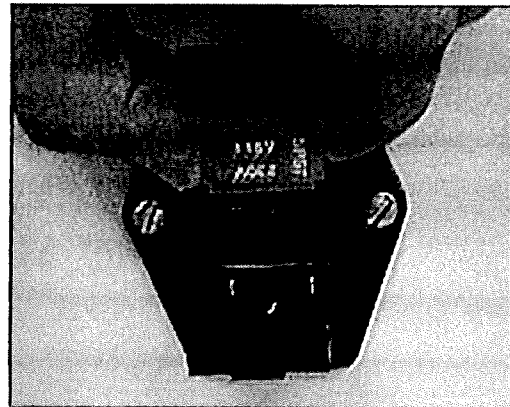

Figure 5.3





## 5.1 HI/LO OR FLEXION/EXTENSION MOTORS (CONTINUED)

### **WARNING**

- Use only the appropriate or listed fusing. Failure to use the stated fuses may result in equipment damage and/or personal injury.

- Remove the blown fuse from the fuse holder and replace it with a new fuse (**Figure 5.4**).

**NOTE:** See **page 13** for fuse rating. If both fuses are blown, replace them.

- Gently push fuse holder back into place on the front of the Power Control Box, ensuring that the voltage mark is on top (**Figure 5.5**). The holder will snap into place.
- Gently lift up and snap the fuse holder cover in place (**Figure 5.6**).

**Important:** If the unit continues to blow fuses contact customer service.

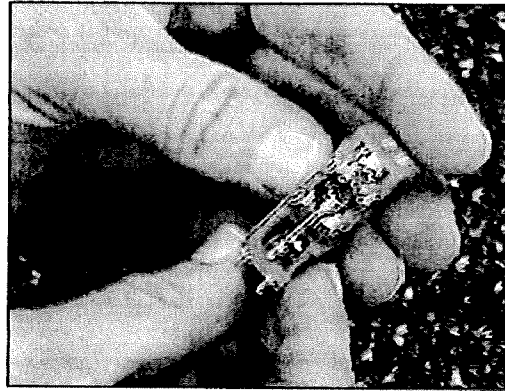

Figure 5.4

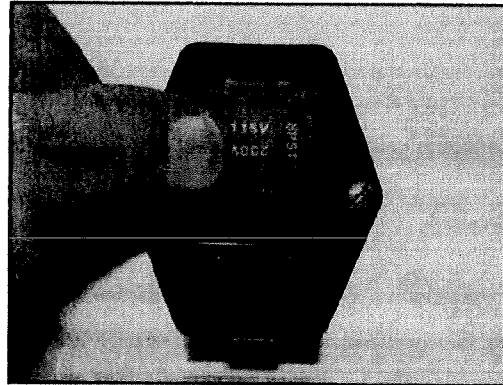

Figure 5.5

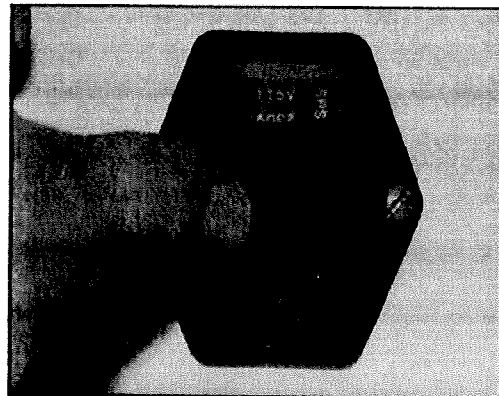

Figure 5.6





## 5.2 PROBLEM SOLVING

**WARNING**

- Disconnect power from the unit prior to servicing.
- Test the unit to verify function after servicing before treating a patient.

PROBLEM	POSSIBLE SOLUTIONS
Cervical stiction - Cervical traction device not operating smoothly	<ul style="list-style-type: none"> <li>- Check for mechanical problem</li> <li>- Are the slide tracks mis-aligned?</li> <li>- Possible debris in slide track</li> <li>- Lubrication maybe required**</li> </ul>
Hi/Lo (hand pendant) or Lumbar up/down is not working or only working intermittently	<ul style="list-style-type: none"> <li>- Check for loose connections under center section at the Power Supply</li> </ul>
<p>Lumbar goes to full extension</p> <p><b>Common errors:</b></p> <p>Slack is not completely taken out of the belts.</p> <p>Harnesses or belts are not snug enough.</p> <p>Multiple layers of clothes or slippery clothes.</p> <p>Placement of belts.</p>	<ul style="list-style-type: none"> <li>- Probable technique issue</li> </ul> <p><b>Examples:</b> Patient doesn't feel traction force or clinician sees that it's at full extension</p> <p><b>Possible solutions for Common errors:</b></p> <ul style="list-style-type: none"> <li>- Slack should be taken out at both the lumbar harness and thoracic harness or slimline belt</li> <li>- Tighten the belts</li> <li>- Belts should be over the skin or over a single layer of cotton clothing (i.e. t-shirt rather than polyester running outfit)</li> <li>- Lumbar harness should be 1" over the iliac crest and the thoracic harness should slightly overlap the lumbar harness</li> </ul>
Lumbar locking mechanism (or gear lock) doesn't lock	<ul style="list-style-type: none"> <li>- Check clearance between gear bar and gear lock plunger when table is in locked position</li> <li>- If the plunger teeth don't fully engage, remove the 2 gear bar screws and insert 1/4" washers as needed</li> </ul>
Lumbar locking mechanism (or gear lock) doesn't unlock	<ul style="list-style-type: none"> <li>- If plunger teeth won't fully disengage, check clearance between gear bar and gear lock plunger when table is in unlocked position</li> <li>- If gear bar is loose, tighten the 2 screws to bring it back into the correct position</li> <li>- Check that plunger is fully retracting when handle is turned and lubricate if necessary</li> <li>- If the gear bar needs to be raised, remove screws and take out washers as required</li> </ul>

\*\*Do not use WD-40. Use silicon or light machine oil only.





## 5.2 PROBLEM SOLVING (CONTINUED)

 <b>WARNING</b>
<ul style="list-style-type: none"> <li>• Disconnect power from the unit prior to servicing.</li> <li>• Test the unit to verify function after servicing.</li> </ul>

PROBLEM	POSSIBLE SOLUTIONS
Rotation/side bending mechanism doesn't lock	<ul style="list-style-type: none"> <li>- Check for any damage, binding or interference in the cable assembly and locking device, 1/8" to 1/4" of free play is needed in the control handle for the cable to retract enough to allow the device to lock</li> <li>- If cables are too tight and there is no free play, loosen brass locking nut and turn the brass threaded (slotted) tube inward or to the right to allow more free play</li> <li>- Do not allow the cable to rest in the slot or it may become damaged (See cable adjusting instructions in manual)</li> </ul>
Rotation/side bending mechanism doesn't unlock	<ul style="list-style-type: none"> <li>- Same procedure as above except the intent is to eliminate any excess free play by turning the brass threaded tube outward or to the left; do not adjust cables any tighter than necessary</li> </ul>
Touch screen displays any error message except 686	<ul style="list-style-type: none"> <li>- Power the table down and turn it back on</li> </ul>
Touch screen displays error message 686	<ul style="list-style-type: none"> <li>- Disconnect power from unit - check for loose connection between the display screen and control box</li> </ul>
Unable to enter treatment information - Touch screen goes back to the welcome screen	<ul style="list-style-type: none"> <li>- Patient safety switch pressed or wires have become disconnected; Solder the wires back in place or replace the patient safety switch</li> </ul>





## 5.3 TRACTION FAILURE

### If the traction unit doesn't work:

- Make sure the unit is getting power.
- Make sure the Patient Control Switch is not physically damaged or something is not pressed against the button.
- If the pump is running, but there is no traction force, check for air leaks between the pump and cylinders (determined by hissing sound during operation).
- If the Touchscreen Control Panel will not accept or hold a command, **STOP** and repair.

## 5.4 SPECIFICATIONS

- EN 60601-1 Electrical Equipment Classification - Class I
- Degree of protection against electrical shock - Type B applied part
- Electrical Ratings: USA - 120VAC, 60 Hz, 5 AMP; Europe: 230VAC, 50 Hz, 3.0 AMP
- Fuse Rating: USA: 125V, T5AL; Europe - 250V, T3AL
- Capacity: 300 pounds (136 kilograms)

## 5.5 ENVIRONMENTAL CONDITIONS

- Normal operating range is between 59° F (15° C) and 95° F (35° C), 20% to 75% relative humidity
- Conditions for storage and transport: -29° F (-34° C) and 149° F (65° C), 15% to 95% relative humidity



TOC





## 6.1 LIGHT BULB REPLACEMENT

This procedure only applies to 3D ActiveTrac devices that have a light bulb in the display box. You will need a 3/16" Allen wrench and needle nose pliers to replace the light bulb. The life of the bulb is approximately 10,000 hours (a little over 1 year if the 3D ActiveTrac is constantly on). For longer bulb life, turn off the 3D ActiveTrac when not in use.

1. Raise table to highest position for easy access. TURN OFF POWER, and unplug power source from the wall.
2. Unscrew the four, 1/4" Allen head screws that secure the display box to the base plate. Hold the control box as you remove the last screws so the box doesn't fall.
3. Lift the display box from the base plate and lay it upside down on the upper part of the table. The cable connecting the display box to the table does not need to be disconnected.
4. Remove the bulb cover by pressing on the tab on the side of the cover as you lift the cover off.
5. Remove the old bulb from the bulb clip with needle nose pliers.
6. Remove the bulb plug as follows: Use the needle nose pliers to depress the tiny tab at the top of the connection as you pull the connection out of the socket. It is ok to gently wiggle the plug as you pull, but take care to avoid damaging the socket.
7. To install the new bulb, reverse the steps above. Gently press the bulb plug into the socket. Snap the bulb into the bulb clip. Snap the cover back into place as you depress the tab on the side of the cover.
8. Reposition the display box and replace and tighten the four, 1/4" Allen screws.

## 6.2 CASTER REPLACEMENT

Elevate unit to take weight off caster. Remove bolt cover cap. Use open end 3/4" wrench to hold nut inside caster yoke and a box or socket wrench to turn bolt from the top of caster support. Remove and replace caster, making sure to tighten nut and bolt completely to assure caster lock works properly. Replace bolt cover.

## 6.3 FOOT/LUMBAR SECTION LOCK ADJUSTMENT

Mirror adjustments may be accomplished by adding or removing 1/4" flat washers between the gear bar and board underneath foot section.

## 6.4 MECK-LOK REPLACEMENT

Note how Meck-lok and cable assemblies are mounted, as well as location, quantity and type of all washers and spacers. Gently pry spring clip cable holder away from the Meck-lok and detach cable assembly. Replace the Meck-lok, making sure to install it so that the cable will pull in the proper direction. (Down for the Side-Bending Meck-lok, and toward the front for the Rotation Meck-lok) Make sure to use nylon washers in the same quantities and locations as the original installation. Fasteners should be tight enough so there is no excess play or movement. Reattach cables to Meck-lok. Make certain spring clip cable holder is securely fastened on Meck-lok. (It should snap into place) Crimp the release lever (cable attachment point) with pliers after the cables are attached in order to secure them in place.





## 6.5 CABLE REPLACEMENT

Note how the cable assembly is connected to the Meck-lok. If two cables are attached to one Meck-lok, one cable will go through the spring clip and one cable will run outside the clip. Gently pry spring clip cable holder away from Meck-lok and detach cable assembly. Remove all cable clamps and mounts.

**NOTE:** Record the location of the cables for reassembly.

Loosen and remove brass adjuster on the control handle. Remove and replace cable assembly. Make certain spring clip cable holder is securely fastened on Meck-lok (it should snap into place). Meck-lok may require the release lever (cable attachment point) to be crimped with pliers after the cables are attached in order to secure them in place. Re-assemble and adjust (**Figure 6.1**).

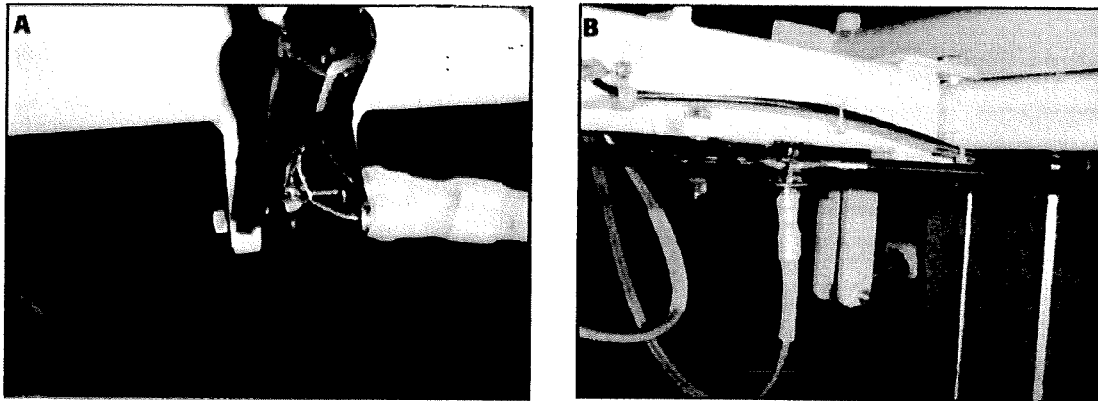

Figure 6.1  
Cable replacement for Meck-lok assembly: A) Rotation; B) Side Bending

## 6.6 CABLE ADJUSTMENT

To adjust cables, loosen the cable clamps closest to control handle. Loosen lock nut on brass adjusters and turn clockwise as far as it will go, then back one turn. Adjust cables to allow 1/8" to 1/4" free play and tighten cable clamps. The Meck-lok should now operate properly. If further adjustment is required, use brass adjuster on control handle. Tighten lock nut on adjuster when adjustment is complete.

## 6.7 COM BOX REPLACEMENT

### CAUTION

When replacing the com box, pull on end piece of plug only. Do not pull on cable.

Remove center upholstered board. Remove power and control cords. Round plugs are twist lock. A special tool is provided with the new com box to remove snap lock cables. Loosen the fasteners holding the box in place. Be sure to support unit until all fasteners are removed to prevent damage to casing. Remove and replace, making sure to reinstall cable clamp and wire bundle on longest bolt. Reconnect all cords and test. Replace upholstered board.







## 6.8 CONTROL BOX REPLACEMENT



### CAUTION

When removing the Control Box, be certain not to loosen any other fasteners on the bottom of the control box by mistake.

Elevate unit enough to allow access to hex nuts under the frame. Note location and position of air hoses and electrical lines, disconnect panelview control box. Remove air hoses from slip lock fitting on cervical and lumbar air cylinders. Remove proximity switch from foot frame. Remove power cord from com box using the special tool provided with new com box. Remove lines and hoses from table frame as required. Carefully cut cable ties where necessary. Loosely roll or otherwise secure wires and hoses with the control box to prevent damage. Locate and remove the mounting nuts, washers and grommets under the control box supports. Carefully remove the control box. Remove any grommets or washers remaining on the old control box. There should be (4) sets of grommets, (8) washers and (4) nuts. Install male grommets in the (4) mounting holes and place a washer on top of each. Install new control box, being very careful to slide all four threaded studs through the center of washers and grommets. Make certain that washers and grommets stay in position and the studs slide straight through the grommets in all four points to avoid damaging them. Use a small amount of tape, if necessary, to hold washers and grommets in place. Install female grommets, washers and nuts under control box supports. Tighten nut until it is even with the tip of the stud. Do not over tighten. Reconnect power cord and air hoses. Reconnect panelview control box. Reinstall proximity switch, making certain to route wire over the top of side bend Meck-lok and clear of foot section locking mechanism.

## 6.9 COLUMN MOTOR REPLACEMENT

Remove center upholstered board. Elevate unit to allow clearance to remove bottom bolts. Use sawhorses or similar devices to support and hold top frame assembly in position. Remove twist lock plug from com box plug #1 and isolate cord so it can be removed. Remove any stick-on tie wrap mounts on column. Remove the (8) socket head screws from the top and bottom of column. Remove and replace column. Socket head screw installation should be as tight as possible and a thread locking product used. Install plug into com box and tie wrap excess cord. Replace stick-on tie wrap mounts as needed. Replace upholstery.

## 6.10 LUMBAR MOTOR REPLACEMENT

Use a sawhorse or similar device to support the lumbar section. Remove twist lock plug from com box plug #2 and isolate cord so it can be removed. Loosen nuts and remove bolts from each end of motor to remove. Install new motor, attaching heavy end first. Plug motor into com box and tie wrap excess cord. Extend motor as needed to line up bolt holes on shaft with motor mounts and reattach.

## 6.11 LUMBAR AIR CYLINDER REPLACEMENT

Remove upholstered footboard. Note location of air fittings on cylinder. Remove air hose from slip lock fitting. Remove large nut from shaft and remove shaft from frame. Be careful not to damage threads on end of shaft. Loosen remaining nut and bolt to remove cylinder. Install new cylinder, making sure that the fitting is in the proper location. Do not over tighten nut on shaft. The shaft should spin freely in cylinder with a minimum amount of play. Push air hose firmly into slip lock fitting. Check for leaks. Replace upholstered footboard.



TOC





## 6.12 CERVICAL UNIT REPLACEMENT

Remove air hose from slip lock fitting, pushing the slip lock toward the cylinder and pulling on the hose. Remove (4) mounting screws from sides of unit, making sure to save the four spacer washers for reinstallation. Replace unit. Push air hose firmly into slip lock fitting and check for leaks.

## 6.13 BEARING REPLACEMENT ON FOOT/LUMBAR SECTION OF TABLE

Loosen nut on bearing mount and rotate. Replace bearing, rotate into position and adjust.

## 6.14 BEARING ADJUSTMENT ON FOOT/LUMBAR SECTION OF TABLE

Remove upholstered surface of foot/lumbar section. Make sure foot/lumbar section is positioned flat and level. Remove air hose from slip lock fitting on lumbar cylinder. Stand at foot end facing the table. Grasp the roller frame on each side at points close to the front bearing mounts. Roll frame forward and backward while applying pressure side to side. Find the point at which there is the least amount of play, hold frame to one side then adjust the appropriate bearing mount to take up the slack. Do not adjust so tight that there is 'drag' during operation. The assembly must roll freely to operate properly. Make certain bearing is straight and aligned with roller track. Repeat for the rear mounts. Be sure all bearing mount retainer nuts are tightened securely after adjustment is complete. Push air hose firmly into slip lock fitting and check for leaks. Replace upholstered surface.

**NOTE:** Miscellaneous parts such as knobs, decals and other self-explanatory items are not included in this information.





## 7.1 UNIT CALIBRATION OVERVIEW

This process is broken down into 5 steps:

- Removing Upholstery
- Aligning the Table
- Connecting the Force Gauge
- Performing Calibration
- Replacing Upholstery

### NOTE:

This explains the calibration procedure for the 3D ActiveTrac, to be performed by a trained technician every 2 years or whenever the calibration of the unit is in question.

### A. Tools and Equipment Required

1. A currently certified (calibrated) force gauge, such as the Chatillon 1150 or equivalent force gauge. The gauge must be capable of measuring greater than 200 pounds with an accuracy of at least  $\pm 0.5\%$  FS (Full Scale) and  $\pm 1$  LSC (Least Significant Count) if the gauge is digital.
2. A means of securely fastening the force gauge to the table, such as a heavy duty strap capable of 200 pounds of tension, with a snap hook closure on one end.
3. A 5/32" hex wrench.
4. A 7/16" socket wrench and 6" extension.

## 7.2 REMOVING UPHOLSTERY

### A. Lumbar

Remove the four screws using a 5/32" hex wrench. These bolts are found near each corner of the rolling lumbar section of the table. The section may need to be moved forward and backward to access these screws.

### B. Thoracic

Remove the four hex head bolts located in the corners under the center frame using a 7/16" socket wrench with 6" extension. Notice that there are spacers between the pad and the frame. When the table is reassembled, these spacers MUST be put back into position. The bolts fit through the holes in the frame, through the spacers and into the upholstery plate.

### C. Face Pads

Use the 7/16" socket wrench to remove the hex head bolts that hold the face pads in place. The left side can be removed completely. The right side will need to remain connected to the adjustment cable assembly.





## 7.3 ALIGNING THE TABLE

Aligning and leveling the table is a very important part of the calibration process. Calibrating a table without proper alignment, will produce invalid results. There are four areas that should be level and straight. These areas are Lumbar (horizontally, rotationally, and side to side), and Cervical.

### A. Lumbar

#### 1. Horizontally

Using the hand held controller, the lumbar section should be raised until the lumbar section is level. Place the level as shown in **Figure 7.1** and adjust table until it is level along the long axis of the table.

#### 2. Rotationally

Using the adjustment handles, the table must be leveled rotationally, or across the table. Place the level as shown in **Figure 7.2** and adjust table until it is level across the table.

#### 3. Side to side (line of sight)

Using a line of sight, ensure that the lumbar portion of the table is positioned in line as much as possible with the thoracic region of the table.

### B. Cervical

Make sure that the cervical unit is positioned level, horizontally. Place the level as shown in **Figure 7.3** and adjust cervical headrest until it is level.

## 7.4 CONNECTING THE FORCE GAUGE

The force gauge should be connected using non-stretchable material, such as lightweight chain. The chain must be able to withstand repeated applications of 200 pounds of force without breaking.

**Figure 7.4** shows how to properly attach the force gauge. The gauge should rest flat on the thoracic region of the table. The handles should be attached as shown. The chain is attached to the handles using appropriate hardware making sure that the force gauge is not put into a bind or twisting when under tension.

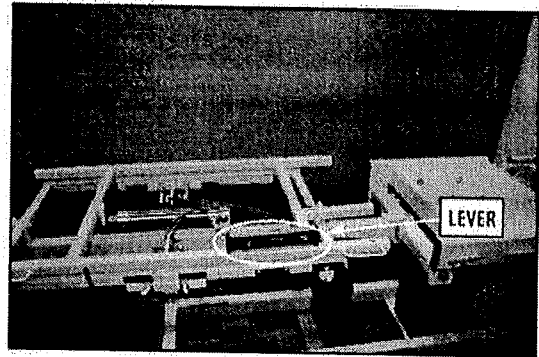

Figure 7.1

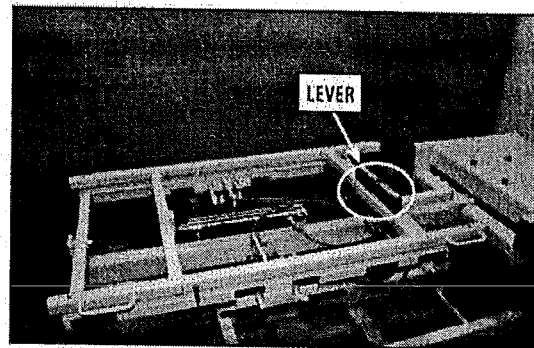

Figure 7.2

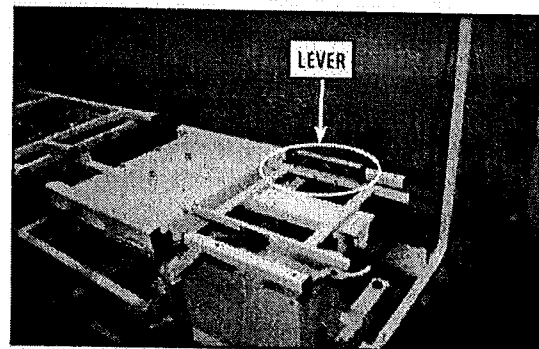

Figure 7.3

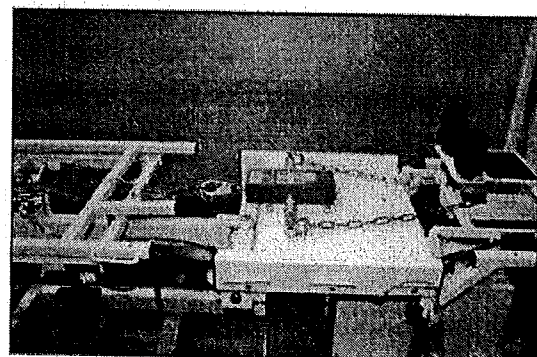

Figure 7.4





## 7.4 CONNECTING THE FORCE GAUGE (CONTINUED)

Both the lumbar and cervical portions of the table should be moved as close together as possible, before the calibration is started. This prevents the sections from reaching their physical limits before the full force is applied to the gauge.

Wrap one end of the chain around the headpiece support. Use a non compressible material such as plastic or heavy cloth around stem of headpiece to prevent paint damage. The other end is attached to the movable portion of the lumbar section.

**NOTE:** Do not wrap the chain around the non-movable portion of the table.

Allow for a small amount of slack in the chain. This prevents "force" from being applied before the calibration is started.

## 7.5 PERFORMING CALIBRATION

### A. General

Using the calibration screen, the operator will be able to enter numeric values at four reference points which will determine the overall accuracy of the traction table (high and low points on lumbar and cervical). Additionally, the operator has the option of calibrating the lumbar or cervical section individually.

The calibration routine must be performed in pounds. If kilograms are the desired units for the table, calibrate it in pounds and the processor will do the conversion. Make sure that the gauge is set to measure pounds and that it is reading zero before the calibration begins. There is a "zero" function on the force gauge. Pressing the "zero" button will cause any residual force on the gauge to be nullified.

### B. Entering Calibration Mode

The calibration screen is accessed by pressing "WELCOME" on the main screen for 5 seconds. (See Figure 7.5) After 5 seconds, the pump will begin running and the calibration screen will appear. (See Figure 7.6)

**NOTE:** To skip lumbar or cervical calibration and retain existing values press "CANCEL" and the next screen will appear. The screens will appear in sequence: Lumbar, Cervical and then return to the "WELCOME" screen. Only pressing the "TEACH" button will save any changes on the screen.

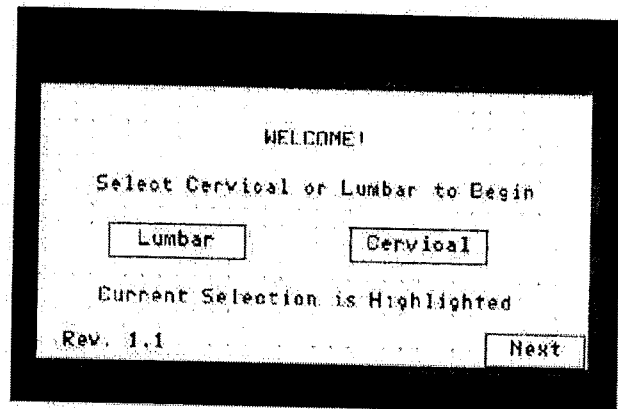

Figure 7.5

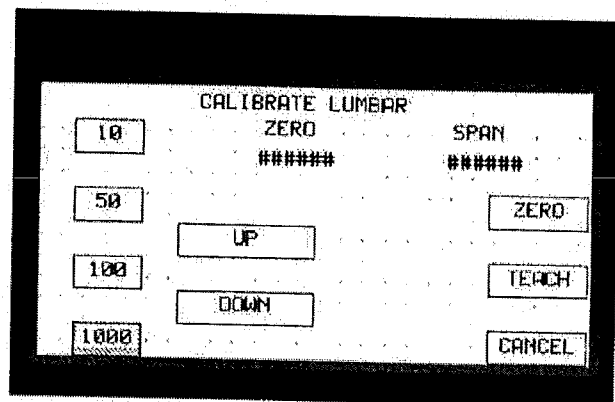

Figure 7.6





## 7.5 PERFORMING CALIBRATION (CONTINUED)

### C. Setting the Lumbar Low Calibration Point (100 pounds)

Press one of the values on the left side of the screen (10, 50, 100 or 1000) to choose the increment value. The increment value determines how much force changes each time the up or down button is pressed. For example, if the 1000 button is chosen, each time "up" is pressed, the value displayed under "ZERO" is increased by 1000. Note that this is not 1000 pounds; it is an electronic reference number. For finer adjustments, choose a lower number for the increment value.

Using the appropriate incremental value, press the "up" button repeatedly, monitoring the force displayed on the force gauge after each adjustment. Continue pressing the "up" button until the force gauge reads exactly 100 pounds. As you get closer to 100 pounds, it is very important to change the increment value to a lower number so that the adjustment is finer. As you get very close to 100 pounds, you should be using the increment value 10 for the finest adjustment. It is very important that the force gauge reads exactly 100 pounds and not over.

If you accidentally exceed 100 pounds, choose a higher increment/decrement value and press the "down" button until the force gauge reads less than 100 pounds. Then choose the increment value of 10 and press the "up" button again until you reach 100 pounds.

Record this value for future reference.

When the force gauge reads exactly 100 pounds, press the "ZERO" button to the right of the screen to store the settings into the controller. The button will now read "SPAN" and the value displayed will be duplicated under the "SPAN" heading.

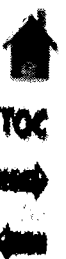



## 7.5 PERFORMING CALIBRATION (CONTINUED)

### D. Setting the Lumbar High Calibration Point (200 pounds)

Using the appropriate incremental value, press the "up" button repeatedly, monitoring the force displayed on the force gauge after each adjustment. Continue pressing the "up" button until the force gauge reads exactly 200 pounds. As you get closer to 200 pounds, it is very important to change the increment value to a lower number so that the adjustment is finer. As you get very close to 200 pounds, you should be using the increment value 10 for the finest adjustment. Once again, it is very important that the force gauge is reading exactly two hundred pounds and not over. When you have successfully adjusted the "SPAN" value, record the value for future reference. If these settings get inadvertently reset, they can be re-entered without having to completely recalibrate the unit. When the force gauge reads exactly 200 pounds, press the "TEACH" button to the right of the screen. All the values will clear out and the screen will reset. Lumbar calibration is complete and you may proceed to calibrate the cervical.

### E. Setting the Cervical Calibration Point (25 pounds)

Calibrate the cervical section the same way as the lumbar section. Use 25 pounds for the "ZERO" set point and 50 pounds for the "SPAN" set point. Once this process has been completed and the numbers recorded press the "TEACH" button. The pump will shut off and the touch panel will return to the main screen.

The unit may now be checked using the procedure for verifying calibration below.

## 7.6 REPLACING UPHOLSTERY

Replace the upholstery in the reverse order of removal. Use caution when installing screws into pads or threaded inserts could be pushed out of place or damaged. Make sure that the fasteners are snug but DO NOT OVERTIGHTEN





## 7.7 VERIFYING CALIBRATION PROCEDURE

Prior to verifying proper calibration, ensure that the table preparation and force gauge connection instructions have been followed.

### A. Lumbar

1. Set a force of 50 pounds on the touch panel. Verify that the force on the gauge reads 50 pounds subject to the tolerances in **Table 2**. Pause the force by pressing the "Pause" button on the touch panel.
2. Increase the force to 100 pounds on the touch panel. Verify that the force on the gauge reads 100 pounds, again, subject to tolerances in **Table 2**.
3. Repeat for 200 pounds.
4. If any of the forces are not accurate, repeat calibration procedure.

### B. Cervical:

1. Set a force of 25 pounds on the touch panel. Verify that the force on the gauge reads 25 pounds, subject to the tolerances in **Table 3**. Pause the force by pressing the "Pause" button on the touch panel.
2. Increase the force to 50 pounds on the touch panel. Verify that the force on the gauge reads 50 pounds, again subject to tolerances in **Table 3**.
3. If any of the forces are not accurate, repeat calibration procedure.

Lumbar Force Tolerances	
Lumbar Set point	Tolerance
11 to 50 pounds	+/- 3 pounds
51 to 100 pounds	+/- 5 pounds
101 to 200 pounds	+/- 7 pounds

Table 2

Cervical Force Tolerances	
Cervical Set point	Tolerance
11 to 25 pounds	+/- 3 pounds
26 to 50 pounds	+/- 4 pounds

Table 3







## 8.1 GENERAL MAINTENANCE

The electric powered 3D ActiveTrac Treatment Table is equipped with two maintenance free, 24-volt DC motors. The pneumatic pump used in the traction unit is a diaphragm pump, which will give many years of trouble free service. Frequently check to make sure all hardware (nuts, bolts, etc.) are securely fastened. Should any problems occur with this unit, contact your authorized 3D ActiveTrac Dealer or call Chattanooga Group at 1-800-266-0026.

If the table is located in an area where it is subjected to extreme amounts of moisture or humidity, the swivel joints on the frame and wheel casters should be lubricated occasionally with a good grade of machine oil.

**Calibration:** The 3D ActiveTrac should be calibrated by a qualified service technician every two years. Contact Chattanooga Group for instructions.

## 8.2 CLEANING

The 3D ActiveTrac vinyl upholstery surface, the Pelvic and Thoracic Harnesses and Slimline Stabilization Belts, and the cervical headstrap may be cleaned with a mild detergent or soap and water. For the table surfaces, apply the solution to a large area and allow to soak for a few minutes. Brisk rubbing with a cloth should remove most dirt. Repeat the procedure in the case of stubborn or embedded dirt. Rinse with clean water. A soft-bristle brush may also be used. The belts and harnesses should be hung to air dry. Between patients, all surfaces should be cleaned using standard cleaning technique, paying particular attention to the components that come in contact with the body.



TOC



# 9- PARTS

3D ACTIVE TRAC®



## 9.1 COLUMN TO BASE

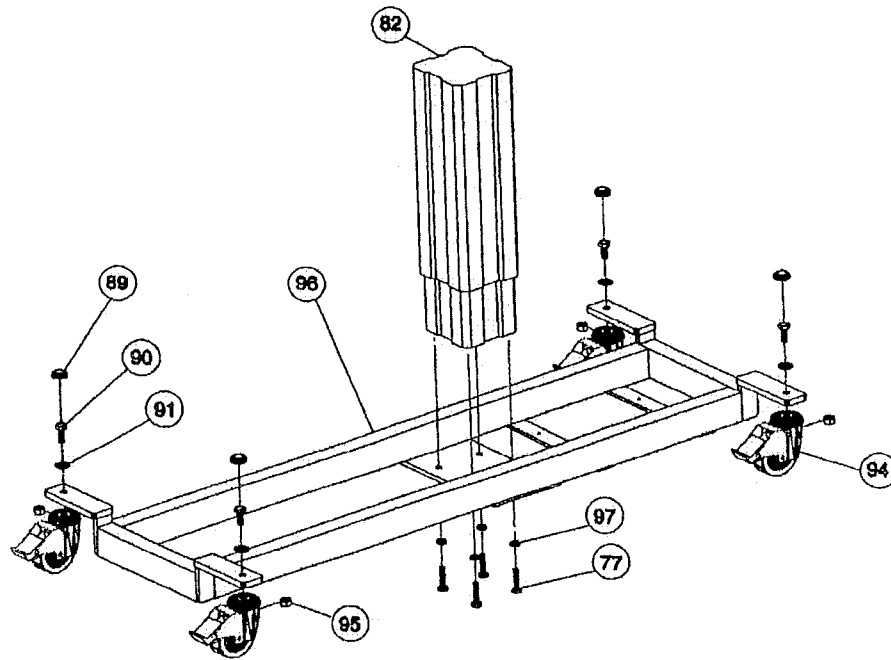

ITEM	PART NO.	DESCRIPTION
77	02079	SCREW SOC HD CAP M10 X 45
82	03236	MOTOR COLUMN TLG TO HILO ACTRAC
89	03012	CAP FINISH BLACK BOLT COVER
90	02102	SCREW FIX HD CAP 1/2-13 X 1-1/2
91	03011	WASHER RHW-207 FINISH CAP
94	03051	CASTER SWIVEL W/BRAKE ACTRAC
95	02095	NUT NYLOCK JAM 1/2-13
96	18353	BASE ACTIVE TRAC PAINTED
97	02103	WASHER HIGH COLLER LOCK M10





## 9.2 FIXED TOP FRAME

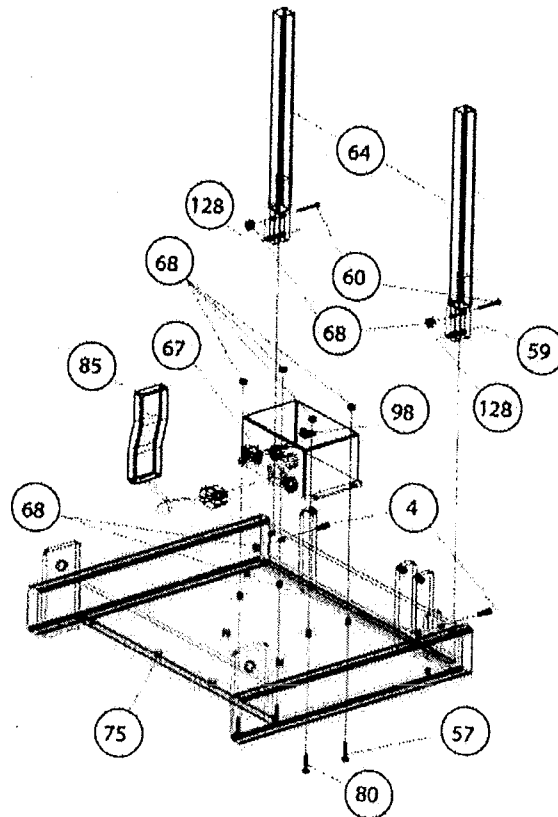

ITEM	PART NO.	DESCRIPTION
4	02027	BOLT EYE 1/4-20 X 1
57	02045	SCREW HX HD CAP 1/4-20 X 1
59	02071	SCREW SET 5/16-18 X 1/4
60	02016	SCREW BTN HD SOC 1/4-20 X 1-3/4
64	18735	TUBE S/A 3DAT ADJ ARMST POST PLTD
67	03238 03239	POWER SUPPLY CONTROL BOX AC TRAC 120V POWER SUPPLY CONTROL BOX AC TRAC 230V
68	02100	NUT NYLOCK 1/4-20
75	18353	FRAME AL TOP FIXED PAINTED
85	03241	SWITCH HAND E/H A 12-PT AC TRAC MOTION
128	02085	SCREW SET 5/16-18 X 5/8





## 9.3 FIXED TOP TO COLUMN

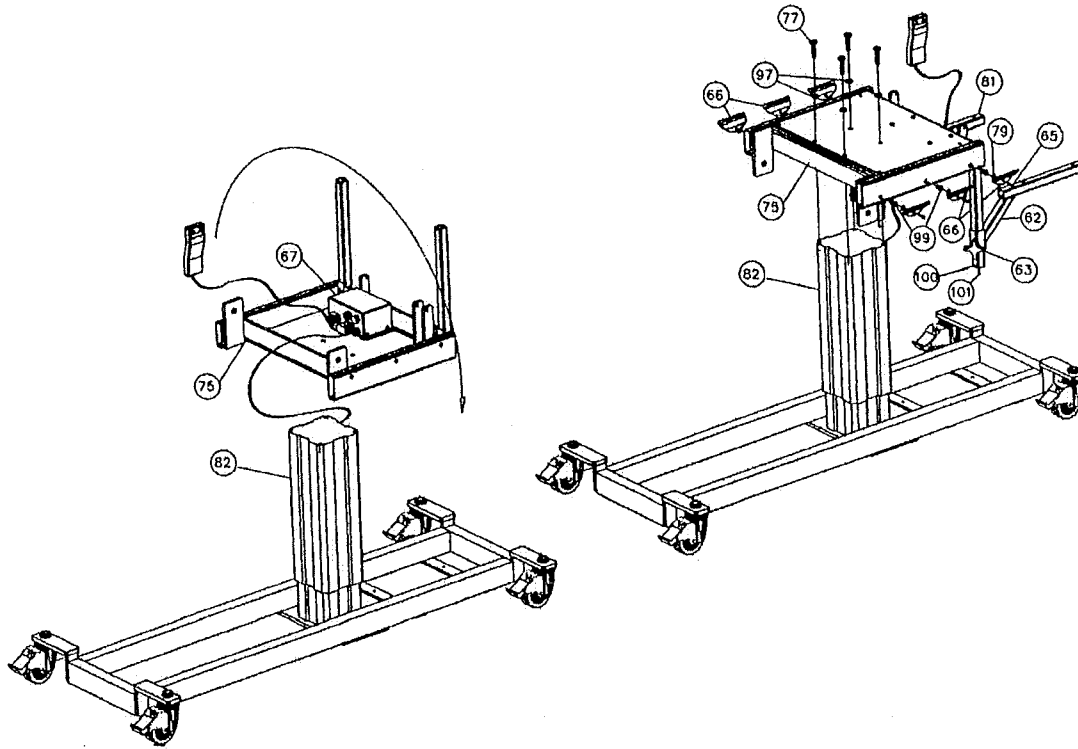

ITEM	PART NO.	DESCRIPTION
62	18731	BRKT 3 DAT ADJ ARMREST LFT PNTD
63	03167	KNOB DK 1 198 5/16 X 1/2
65	02037	SCREW BTN HD SOC 1/4-20 X 1
66	12320	PLT HALF RD 14GA X 3- 5/8 AT STRAP PNT
67	03238 03239	POWER SUPPLY CONTROL BOX ACTRAC 120V POWER SUPPLY CONTROL BOX ACTRAC 230V
75	18395	FRAME AT TOP FIXED PAINTED
77	02079	SCREW SOC HD CAP M10 X 45
79	02160	WASHER NYLON 5/16 ID
81	18733	BRKT 3DAT ADJ ARMREST RT PNTD
82	03236	MOTOR COLUMN TLG 10 HILO ACTRAC
97	02103	WASHER HIGH COLLER LOCK M10
99	03080	RIV NUT 1/4-20 14GA
100	02078	SCREW PAN HD PHIL 10-32 X 3/8
101	02089	NUT NYLOCK 10-32



TOC





**9.4 HEAD SECTION**

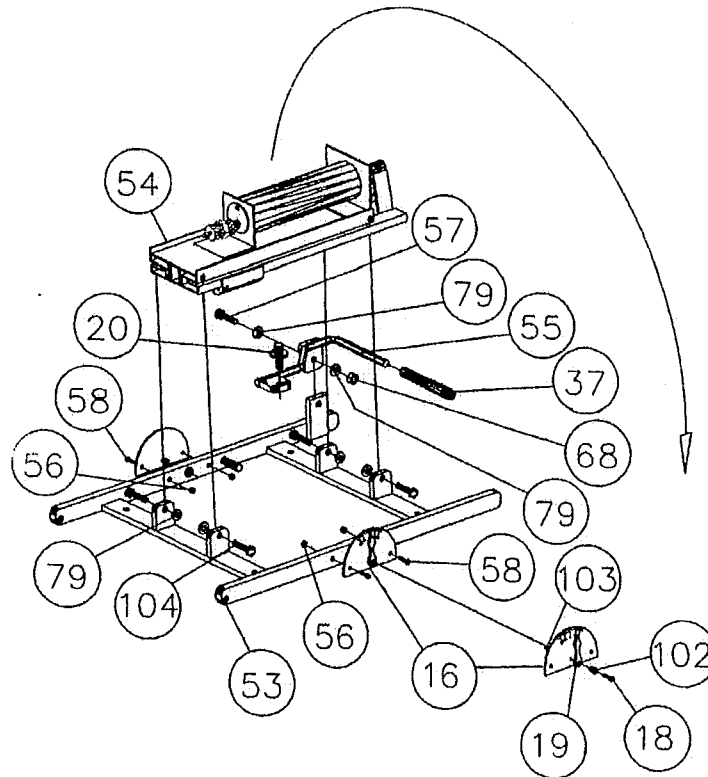

ITEM	PART NO.	DESCRIPTION
16	12314	GAUGE ALUM ACTRAC HEAD ANGLE
18	02008	SCREW PAN HD 4-40 X 1/2
19	03224	POINTER HEAD ANGLE ACTRAC
20	03128	ADJUSTABLE CABLE TENSION 8MM
37	03013	CAP .312 X 4 BLK PLASTIC TUBE
53	18364	FRAME HEAD SEC ACTRAC PAINTED
54	03093	CERVICAL UNIT W/DELUXE HEAD PIECE
55	18368	HANDLE CERVICAL ADJUST ACTRAC PNTD
56	02093	NUT NYLOCK 8-32
57	02045	SCREW HX HD CAP 1/4-20 X 1
58	02107	SCREW PAN HD PHIL 8-32 X 3/4
68	02100	NUT NYLOCK 1/4-20
79	02160	WASHER NYLON 5/16 ID
102	02113	STANDOFF SPACER GAUGE
103	02112	NUT NYLOCK 4-40
104	02114	SCREW HX HD CAP 1/4-20 X 3/4





## 9.5 UNDER FRAME INSTALLATIONS

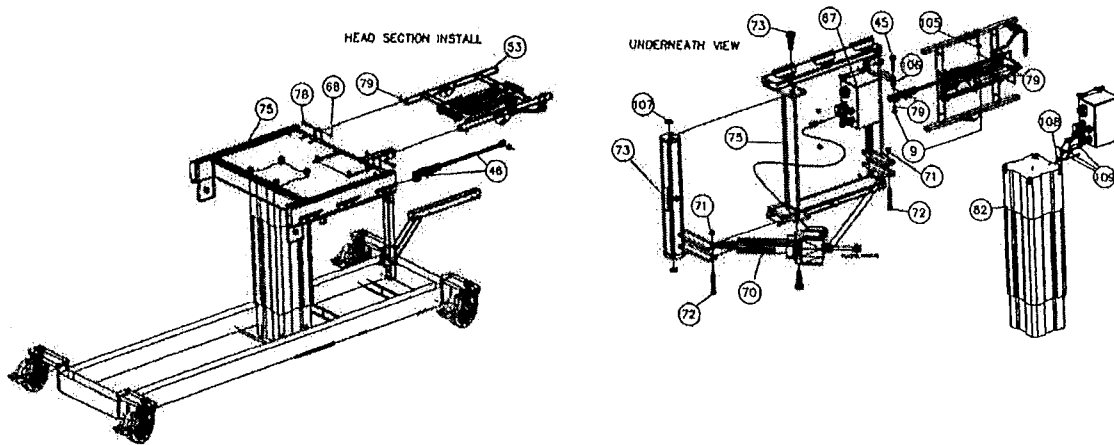

ITEM	PART NO.	DESCRIPTION
9	02105	NUT NYLOCK 5/16-18
45	02055	SCREW HX HD CAP 5/16-18 X 2
46	03230	MECKLOK MM65-1275
53	18364	FRAME HEAD SEC ACTRAC PAINTED
67	03238 03239	POWER SUPPLY CONTROL BOX ACTRAC 120V POWER SUPPLY CONTROL BOX ACTRAC 230V
68	02100	NUT NYLOCK 1/4-20
70	03237	MOTOR MAX10 ACTRAC TAIL
71	02092	NUT NYLOCK M8-1.25
72	02026	BOLT SHLDR M10 X 50
73	18358	TUBE 2 X 2 X 19 TAIL PIVOT PAINTED
75	18355	FRAME AT TOP FIXED PAINTED
78	02005	BOLT SHLDR 5/16 X 3/4
79	02160	WASHER NYLON 5/16 ID
82	03236	MOTOR COLUMN TEG 10 HILO ACTRAC
105	02130	NUT HX FIN 5/16-18
106	02138	NUT HX FIN 3/8-16
107	02167	WASHER NYLON 5/8 ID
108	02204	CABLE TIE ADHESIVE MOUNT
109	02236	CABLE TIE 1/16" X 8"





**9.6 TAIL TUBE INSTALLATION**

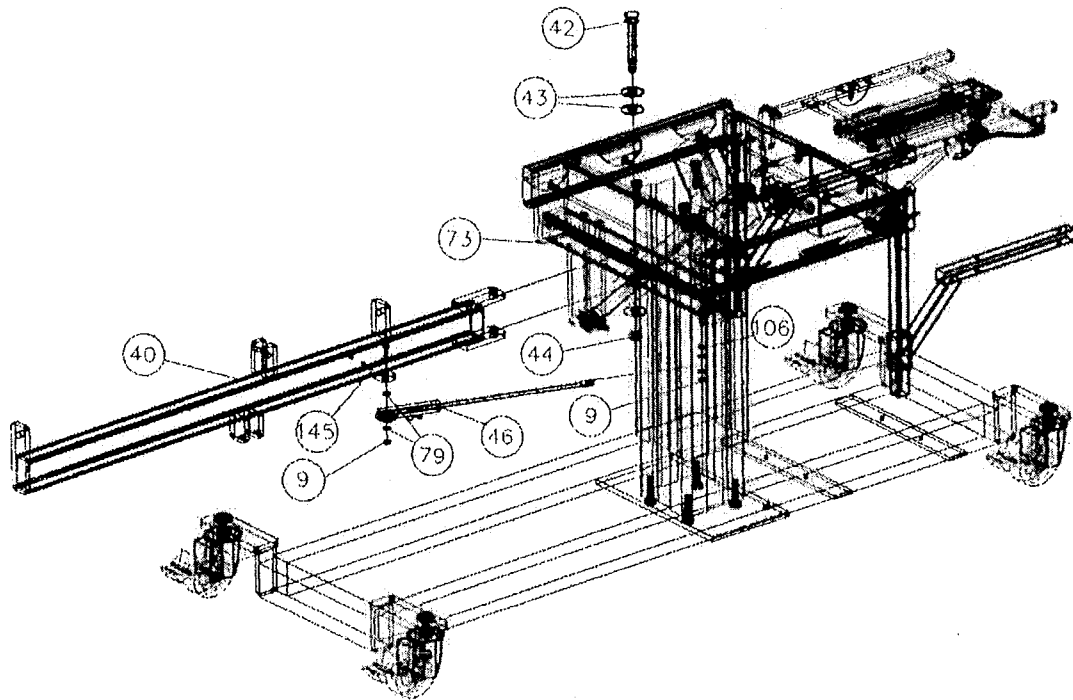

ITEM	PART NO.	DESCRIPTION
9	02105	NUT NYLOCK 5/16- 18
40	18310	TUBE TAIL ACTRAC WELDED PAINTED
42	02021	BOLT SHLDR 5/8 X 3-1/4
43	02156	WASHER FLAT 5/8 PLATED
44	02090	NUT NYLOCK 1/2- 13
46	03230	MECKLOK MM65-1275
73	18358	TUBE 2 X 2 X 19 TAIL PIVOT PAINTED
79	02160	WASHER NYLON 5/16 ID
106	02138	NUT HX FIN 3/8- 16
145	02050	SCREW HX HD CAP 5/16-18 X 1- 3/4





**9.7 LOWER LUMBAR SECTION**

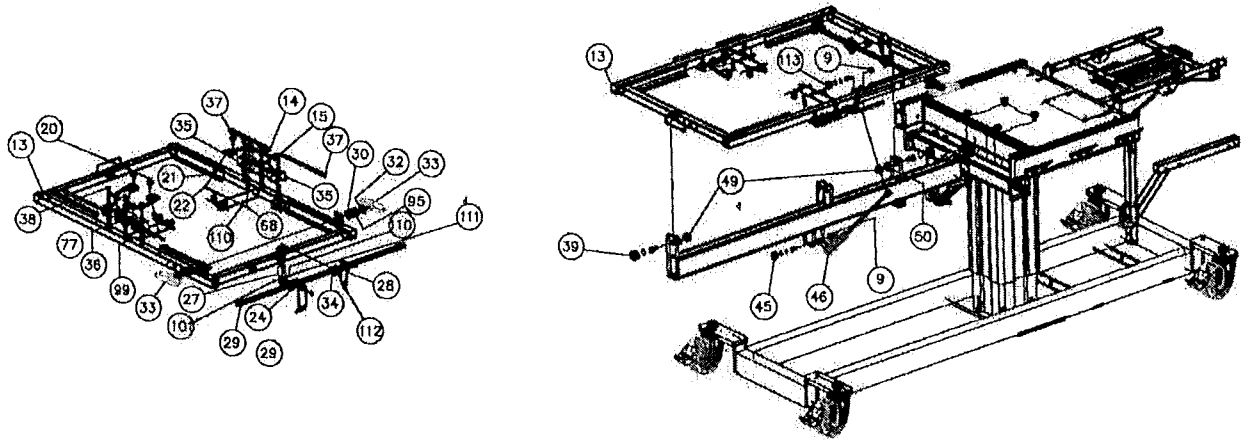

ITEM	PART NO.	DESCRIPTION	ITEM	PART NO.	DESCRIPTION
9	02105	NUT NYLOCK 5/16- 18	35	11317	BLOCK 1 X 1.25 X 1.5 AT UHMW HNDL SPPT
10	03010	PLUG 1 X 1 X 14GA	36	11318	BLOCK 1 X 1.25 X 2.25 AT UHMW HNDL SPPT
13	18301	FRAME ACTRAC FT LOWER PNTD	37	03013	CAP .312 X 4 BLK PLASTIC TUBE
14	18366	HANDLE ACTRAC BODY SEC RIGHT PNTD	38	02073	SCREW FLT HD PHIL 1/4-20 X 1-1/2
15	18360	HANDLE ACTRAC BODY SEC LEFT PNTD	39	02017	BOLT SHLDR 1/2 X 1-1/2
20	03128	ADJUSTER CABLE TENSION 8MM	45	02055	SCREW HX HD CAP 5/16-18 X 2
21	02098	SPRING M25	46	03230	MECHLOK MM65-1275
22	02096	SCREW PAN HD PHIL .32 X S-1/2	49	02110	NUT NYLOCK 3/8-16
24	13307	BUSH 1" OD X 33/64 ID X 1-1/4 AT LK PLTD	50	02165	WASHER NYLON 1/2 ID
27	12519	GEAR RACK PLUNGER LOCK PLTD	77	02079	SCREW SOC HD CAP M10 X 45
28	12527	BAR 1/8 X 1-1/4 X 3-1/8 LNKAG LOK MECH	95	02095	NUT NYLOCK JAM 1/2-13
29	13521	ROD 1/2 X 23 THD'D 400 CAM LOCK PLTD	99	03080	RIV NUT 1/4-20 14GA
30	13095	SPACER 5/16 X 5/8 X 5/8 WHITE PLASTIC	101	02089	NUT NYLOCK 10-32
32	02135	NUT HX FIN JAM 1/2-13	110	02097	NUT HX FIN 10-32
33	03070	KNOB WING 1/2 X 13 ID	111	02101	SCREW PAN HD PHIL 10-32 X 1
34	13513	BUSH CAM RACK LOCK MECH PLTD	112	02153	SCREW SET 1/4-20 X 3/4
			113	02062	SCREW HX CAP 5/16-18 X 1-1/2







## 9.8 ROLLER FRAME

STEP 24

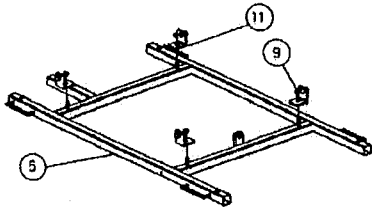

STEPS 25-28

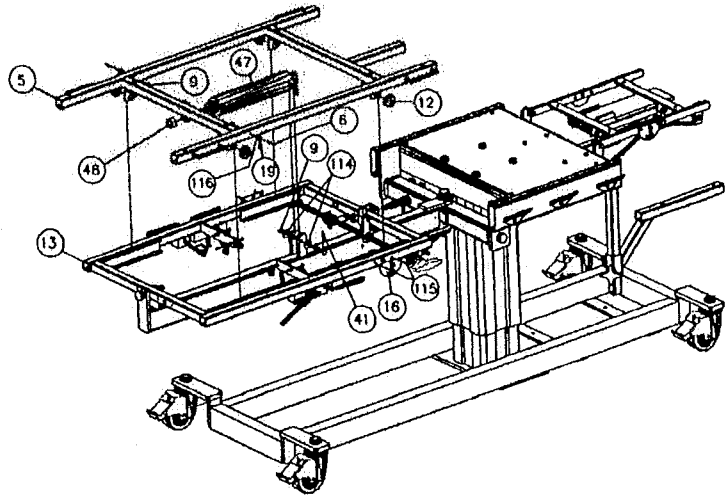

ITEM	PART NO.	DESCRIPTION
5	18312	FRAME ACTRAC FT UPPER PAINTED
6	02056	SCREW PAN.HD PHIL 6-32 X 1-5/8
9	02105	NUT NYLOCK 5/16-18
11	18321	ANG 1-1/2 SQ X 1-1/4 ACTRAC BRG PLTD
12	03066	BEARING KILLIAN F300 1/2 ID 1-18
13	18301	FRAME ACTRAC FT LOWER PNTD
16	12314	GAUGE ALUM ACTRAC HEAD ANGLE
19	03221	POINTER HEAD ANGLE ACTRAC
41	02011	BOLT SHLDR 3/8 X 1-3/4
47	03132	CYLINDER 316-13XP 2B 6.0S DBL ACT TR
48	02091	NUT NYLOCK 1/2-20 THIN PATTERN JAM
114	02150	WASHER 5/16
115	02007	SCREW HX WASHER HD #8 X 3/4
116	02142	WASHER FLAT #6



## 9.9 ELECTRONICS PACKAGE

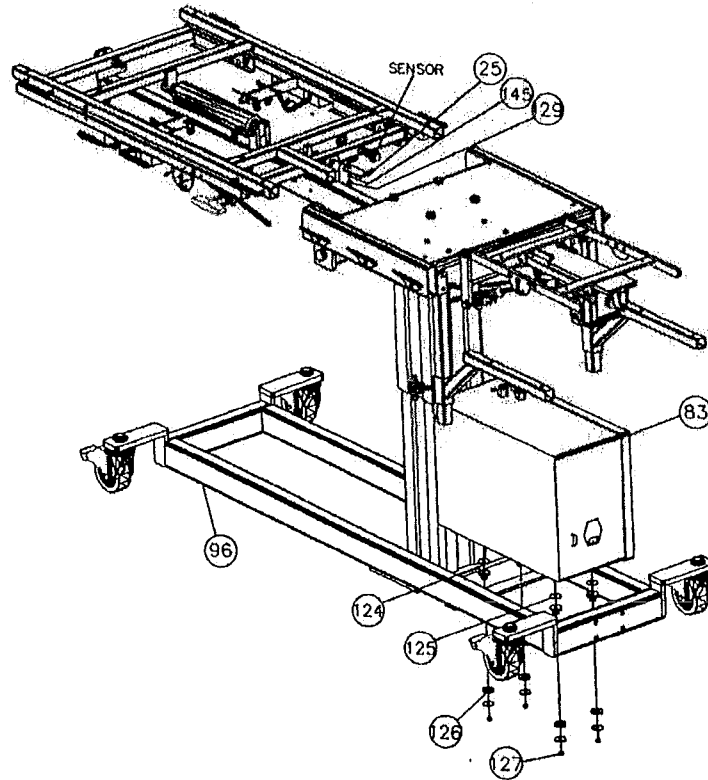

ITEM	PART NO.	DESCRIPTION
25	12317	BAR 1/8 X 1 X 3-1/2 AT SENSOR ACTV PLTD
83	03100** 03101**	ELECTRICAL PACKAGE ACTRAC 120V ELECTRICAL PACKAGE ACTRAC 230V
96	18353	BASE ACTIVETRAC PAINTED
124	03135	GROMMET RUBBER BUSHING SB-4
125	02143	WASHER FENDER 1/4"ID X 1"OD
126	03134	GROMMET RUBBER BUSHING SB-3
127	02084	NUT NYLOCK JAM 1/4-20
129	02111	NUT HX PIN JAM 5/16-18
145	02050	SCREW HX HD CAP 5/16-18 X 1-3/4

\*\* May include some parts also listed separately.





9.10 LUMBAR GEAR LOCK UPHOLSTERY-END CAPS

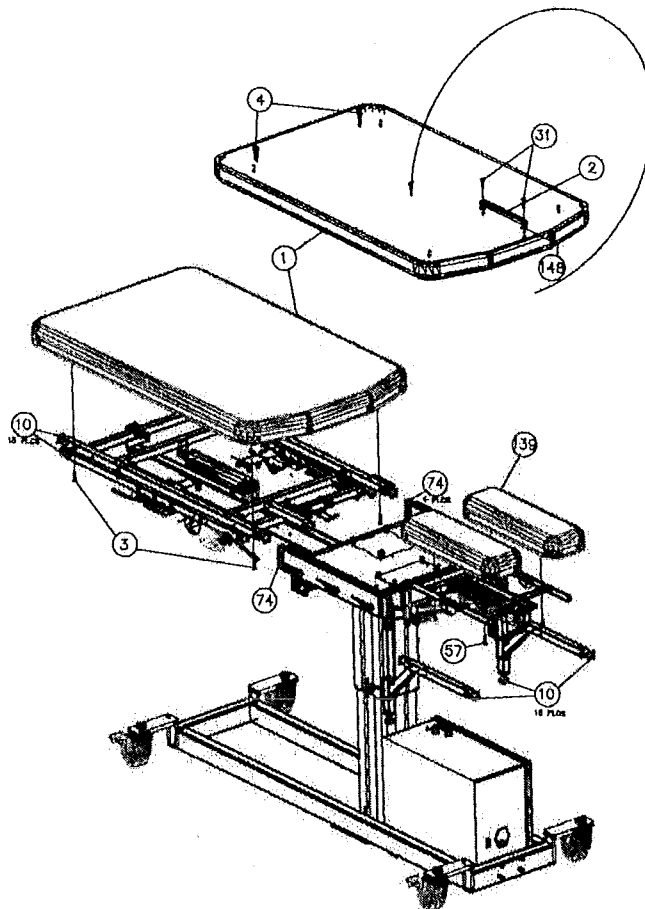

ITEM	PART NO.	DESCRIPTION
1	14831	BD UPH ACTRAC FOOT
2	12311	BAR GEAR 1/2 SQ X 7-3/4 AT LOCK PLTD
3	02067	SCREW FLT HD SOC 1/4-20 X 1-3/4
4	02027	BOLT EYE 1/4-20 X 1
10	03010	PLUG 1 X 1 X 14GA
38	02073	SCREW FLT HD PHIL 1/4-20 X 1-1/2
57	02045	SCREW HX HD CAP 1/4-20 X 1
74	03016	PLUG 1 X 3 X 14GA
139	14833	BD UPH HEAD ACTRAC
148	02140	WASHER 1/4



TOC



9.11 UPHOLSTERY AND TOUCH SCREEN

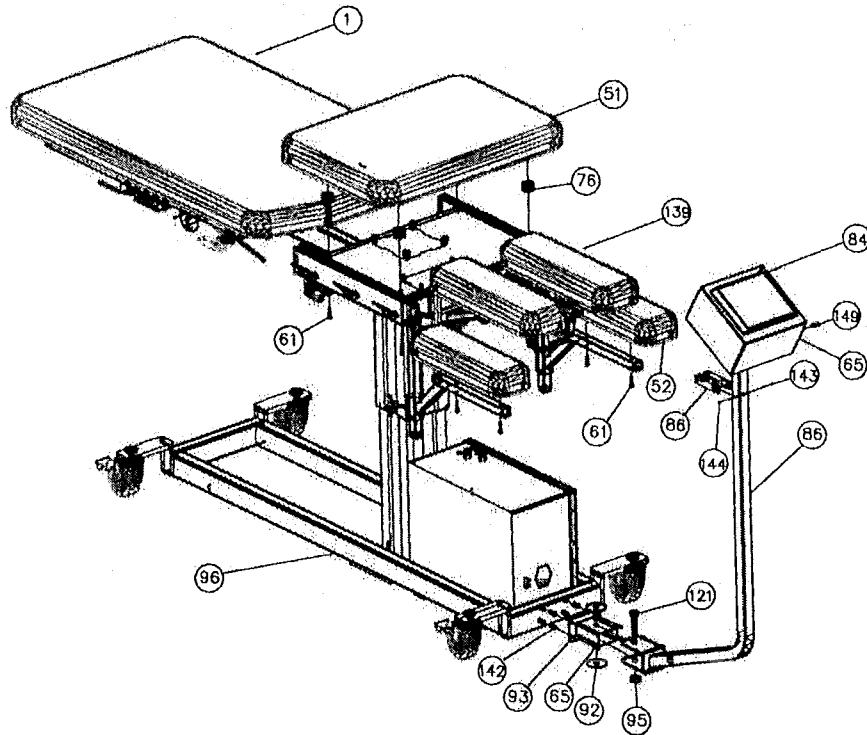

ITEM	PART NO.	DESCRIPTION	QTY
1	14831	BD UPH ACTRAC FOOT	
3	02067	SCREW FLT HD SOC 1/4- 20 X 1-3/4	
51	14830	BD UPH ACTRAC CENTER SECTION	
52	14832	BD UPH ARMREST ACTRAC	
61	02054	SCREW HX HD CAP 1/4- 20 X 1-3/4	
65	02037	SCREW BTN HD SOC 1/4- 20 X 1	
76	02166	SPACER NYLON 1-1/4 OD X 17/64 ID X 3/4	
84	**	PANEL VIEW	
86	12398	BLOCK UHMW AT HOLSTER PATIENT SWITC	
92	13096	WASHER UHMW 1/8 X 2" OD X 9/16" ID AT SWV	
93	18739	BRKT AT SWIVEL STAND SPPT PNTD	
95	02095	NUT NYLOCK JAM 1/2-13	
96	18353	BASE ACTIVETRAC PAINTED	
121	02047	SCREW HX HD CAP 1/2-13 X 2-3/4	
139	14833	BH UPH HEAD ACTRAC	
142	03083	RIV NUT 1/4-20-11GA	
143	02108	SCREW PAN HD PHIL 10-24 X 2	
144	02136	NUT HEX CAP 10-24	
149	03075	KNOB W/STEM 1/4-20 X 1/2	

\*\* May include some parts also listed separately.

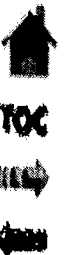



## 10.1 PANEL LAYOUT 3DAT CONTROL BOX

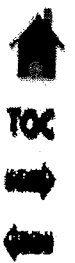
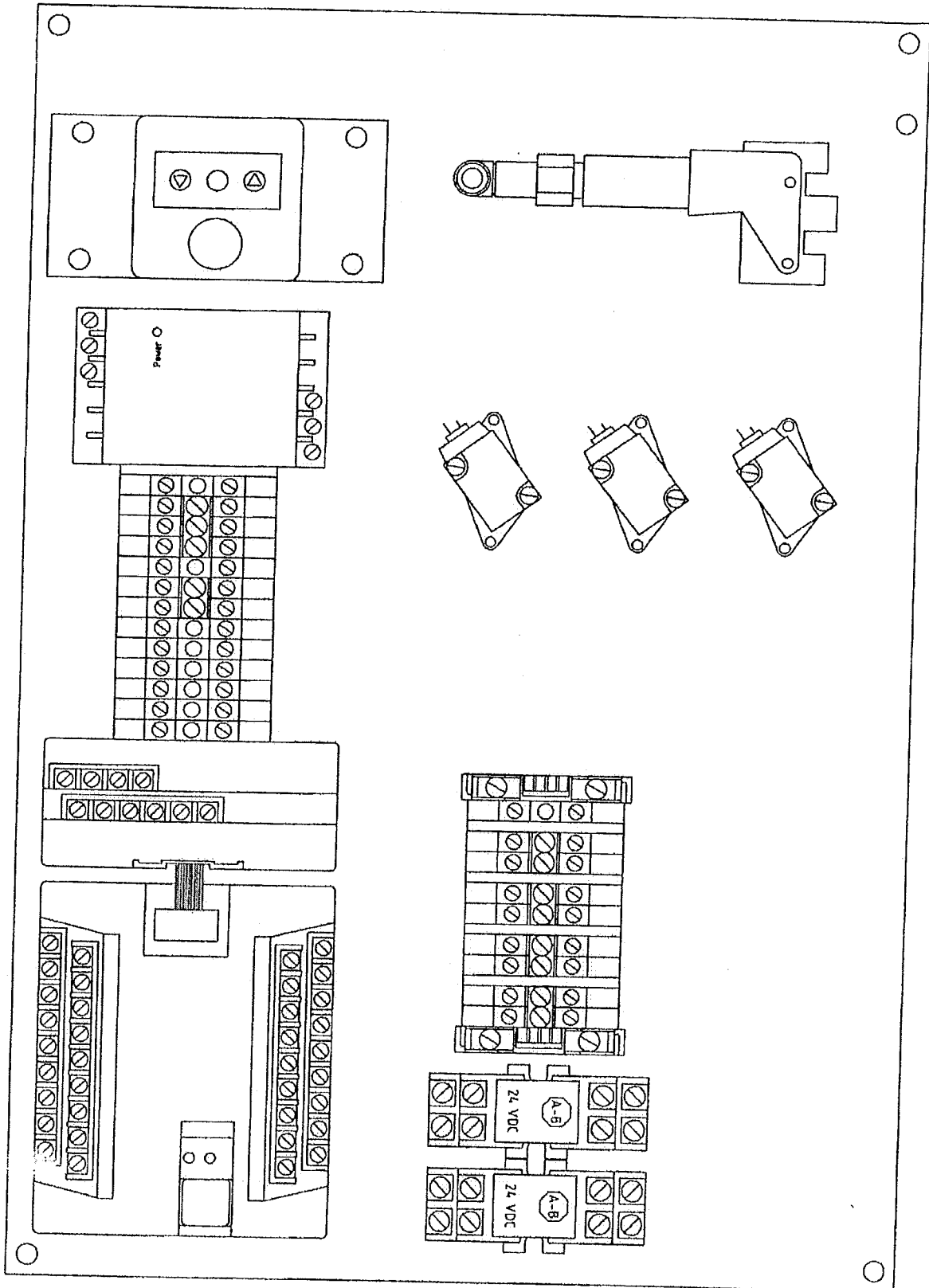



## 10.2 BOX CONTROL 3DAT LOWER RIGHT SIDE

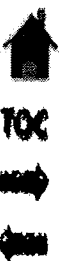
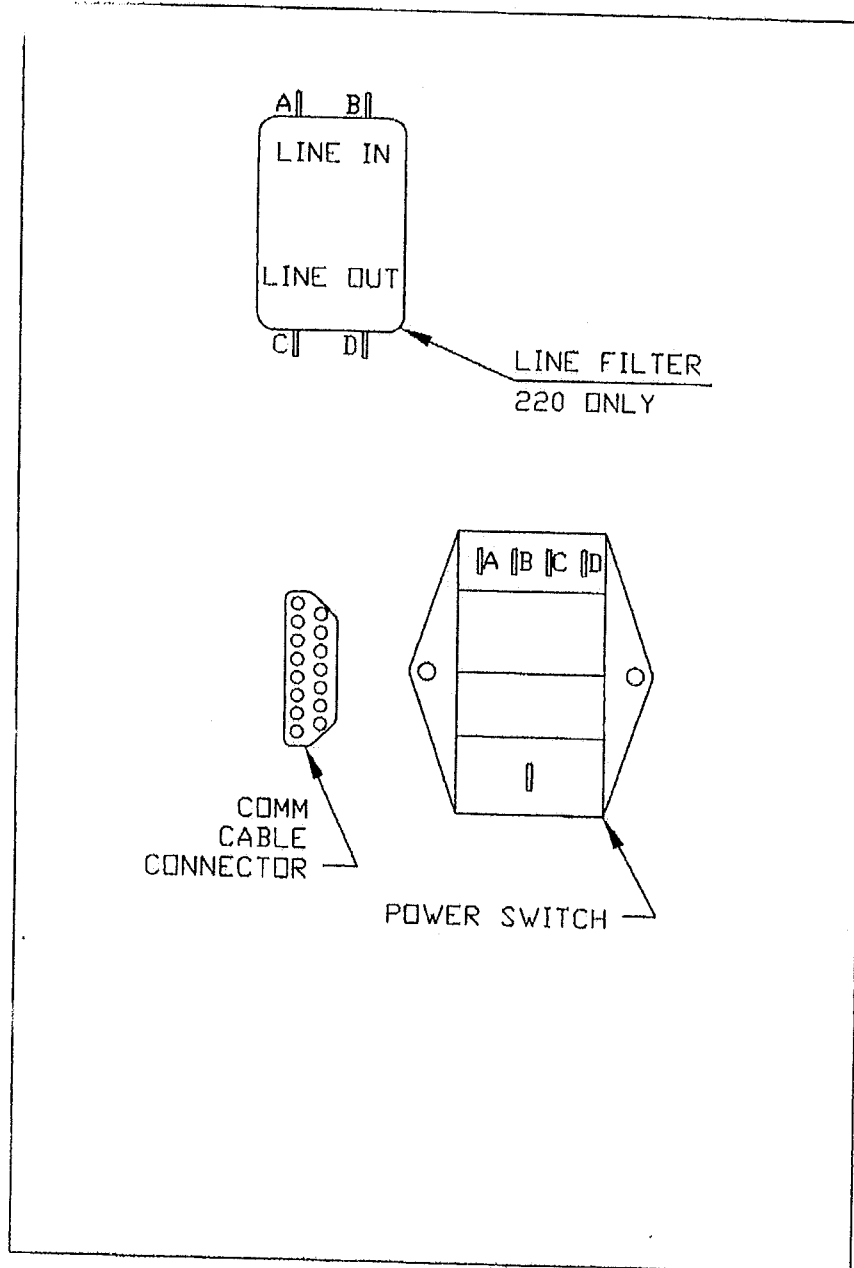



## 10.3 BOX CONTROL 3 DAT LOWER TOP SIDE

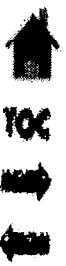
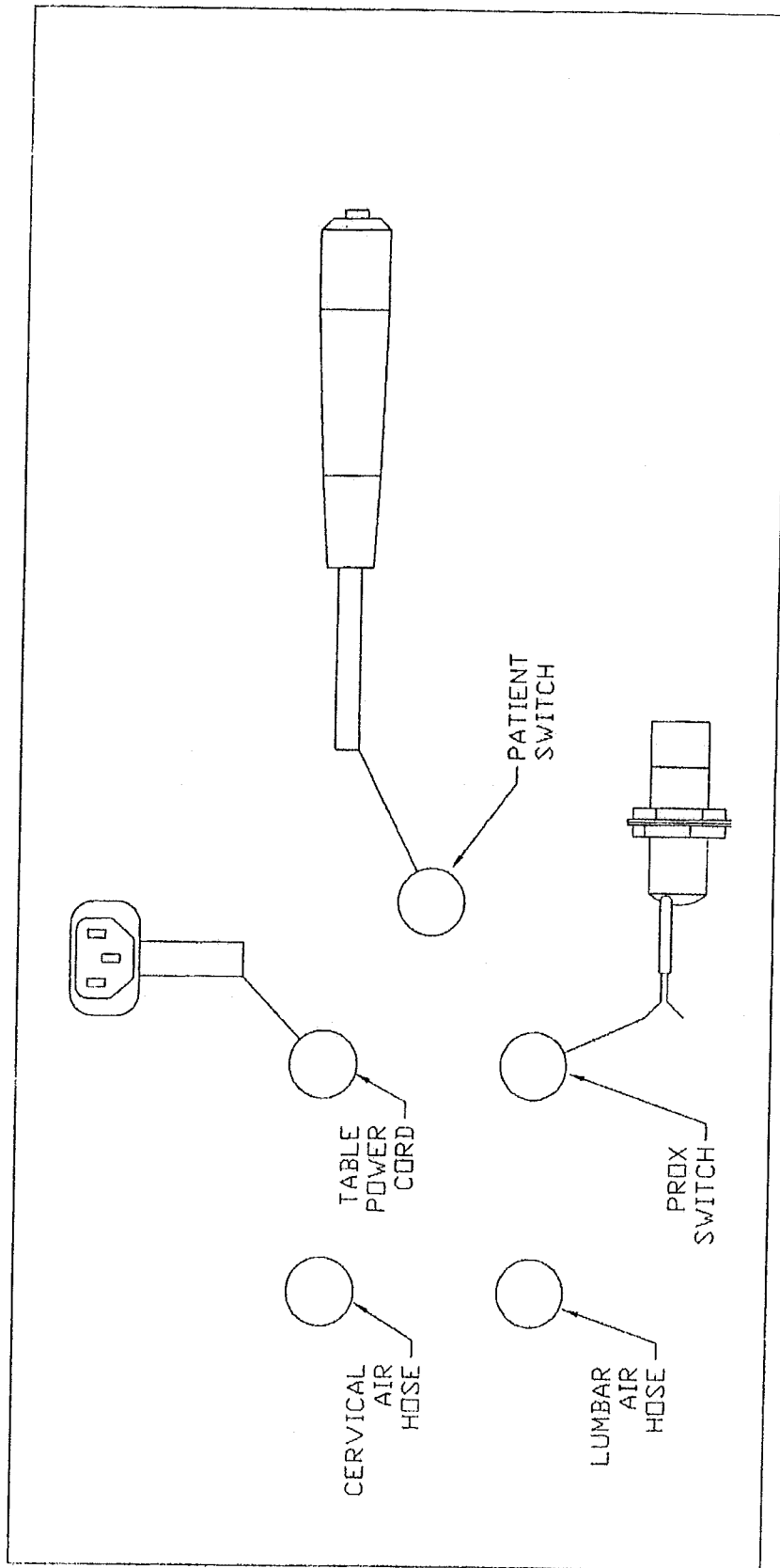



## 10.4 BOX CONTROL 3 DAT LOWER BOTTOM

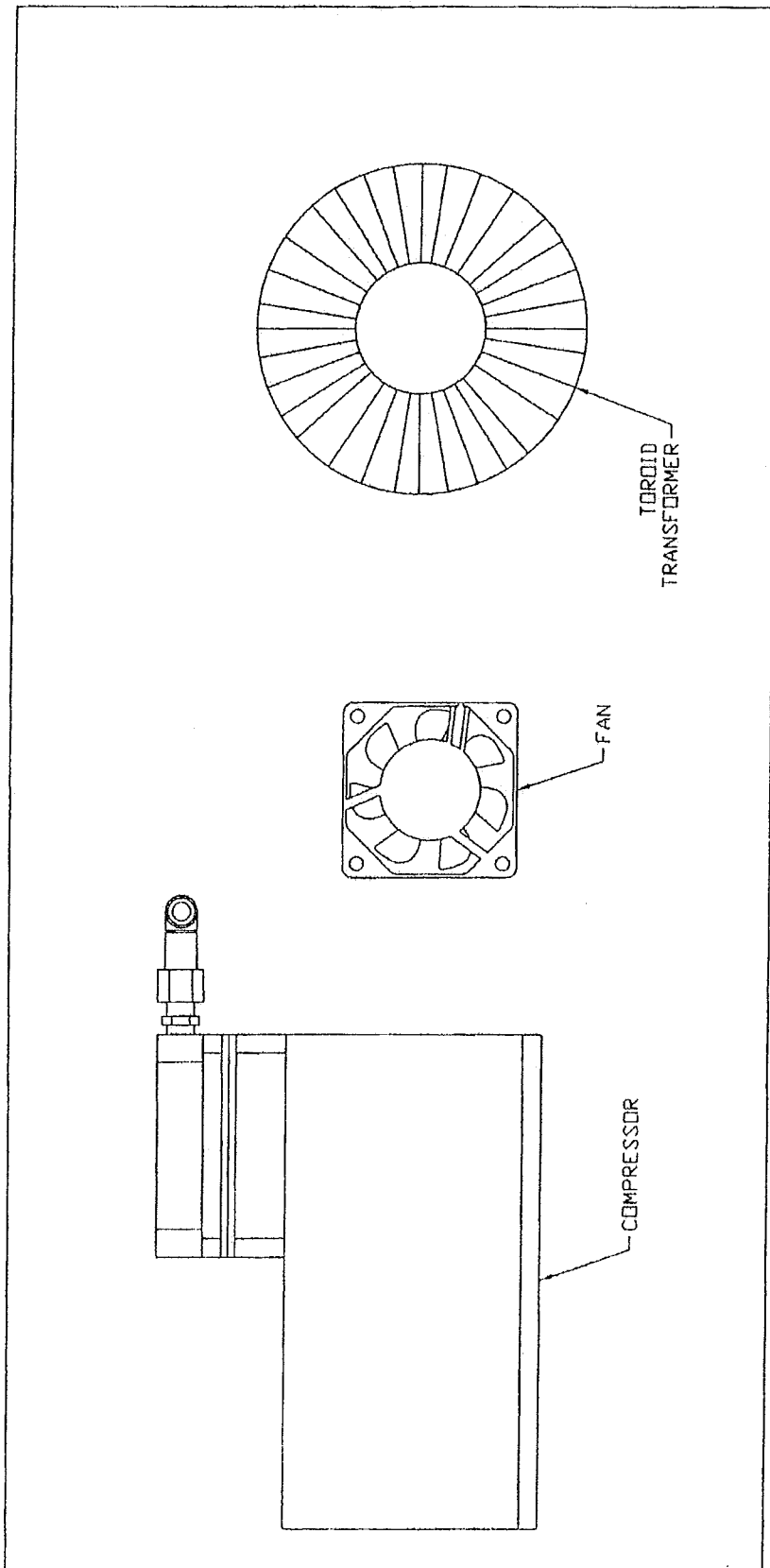





## 10.6 CONTROLLER 3DAT MICROLOGIX

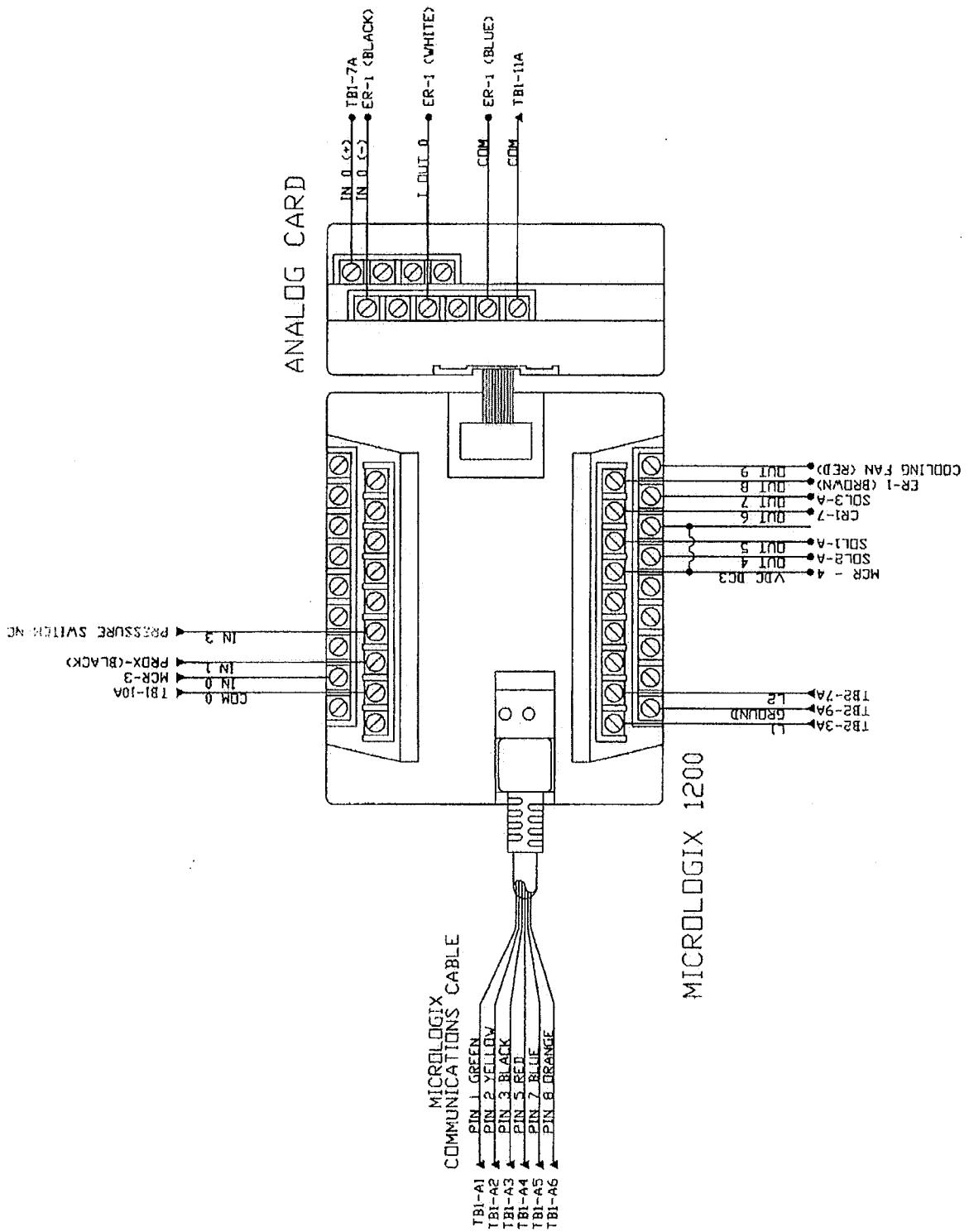



## 10.7 CONTROLLER CDAT MICROLOGIX

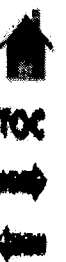
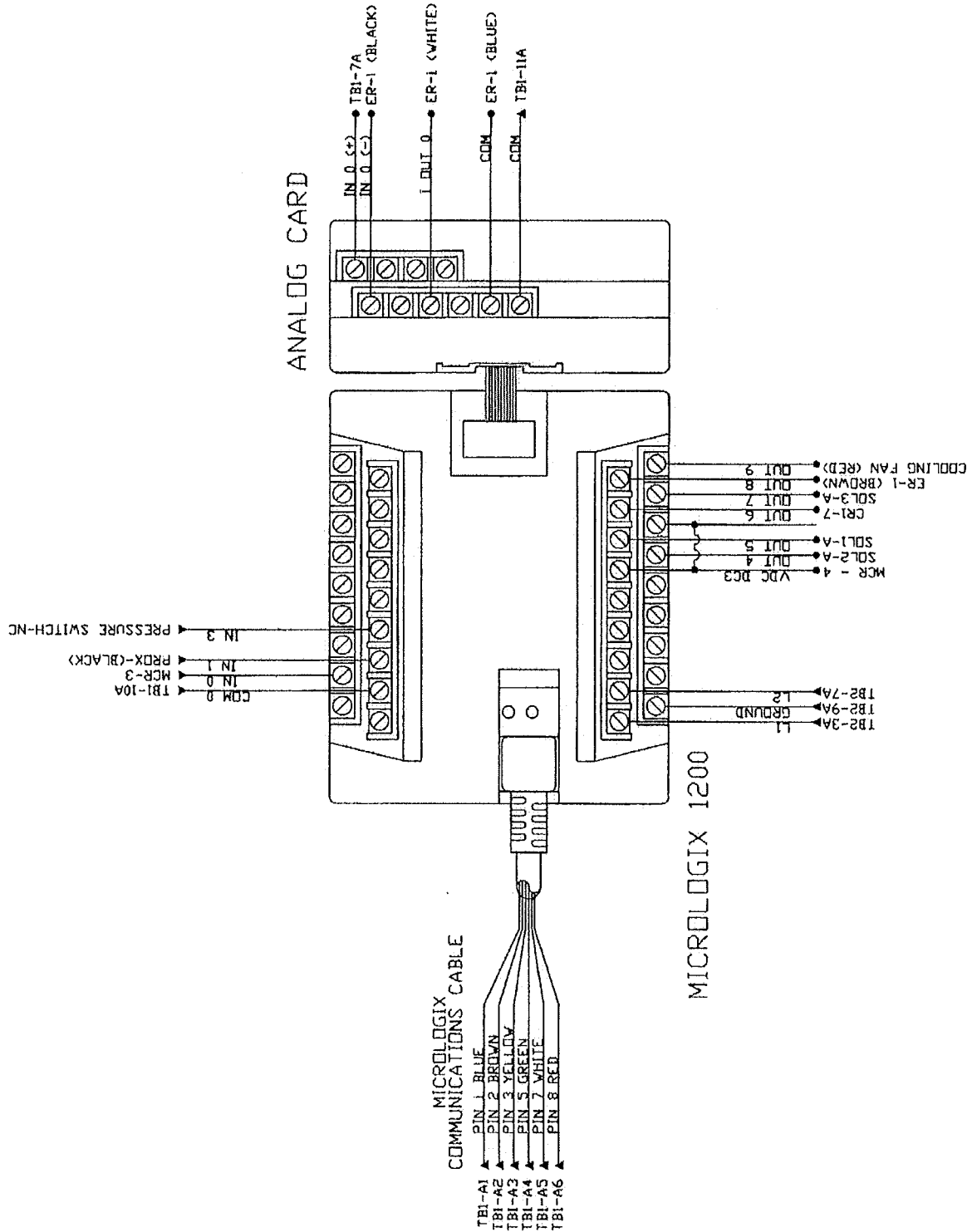



## 10.8 CONTROLLER 3DAT MICROLOGIX 230

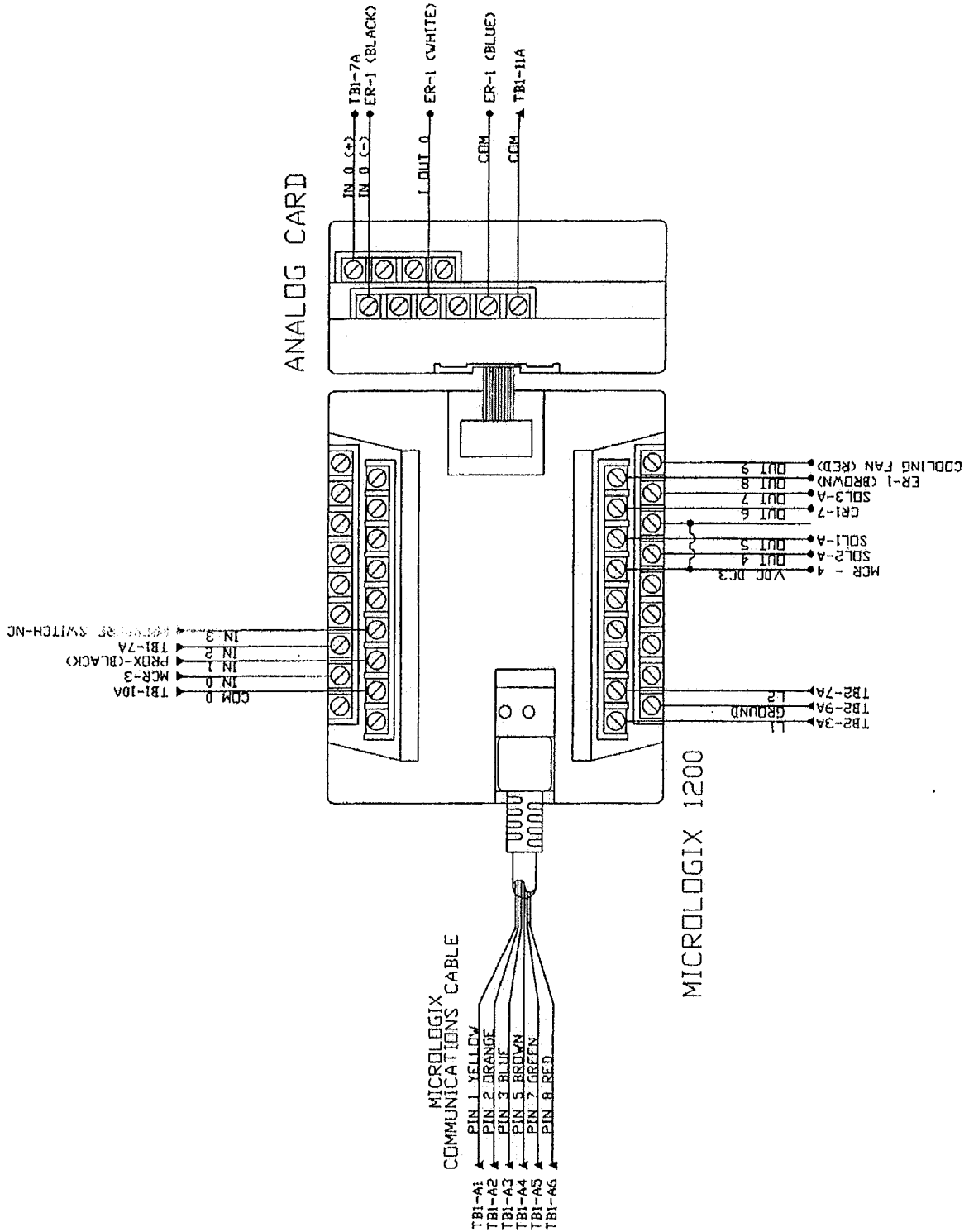



## 10.9 CONTROLLER 3DAT MICROLOGIX 230

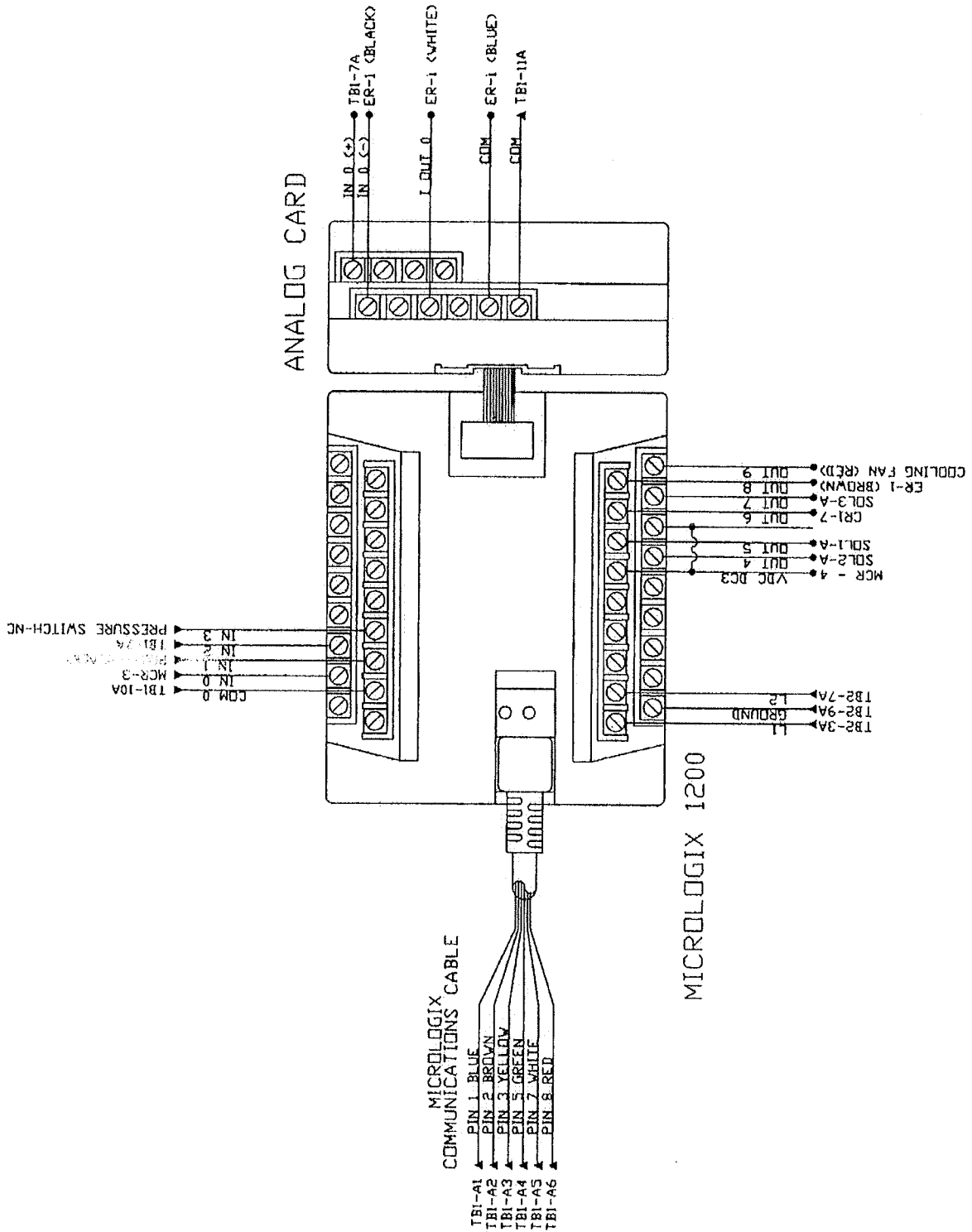



## 10.10 CONTROLLER 3DAT MICROLOGIX 230

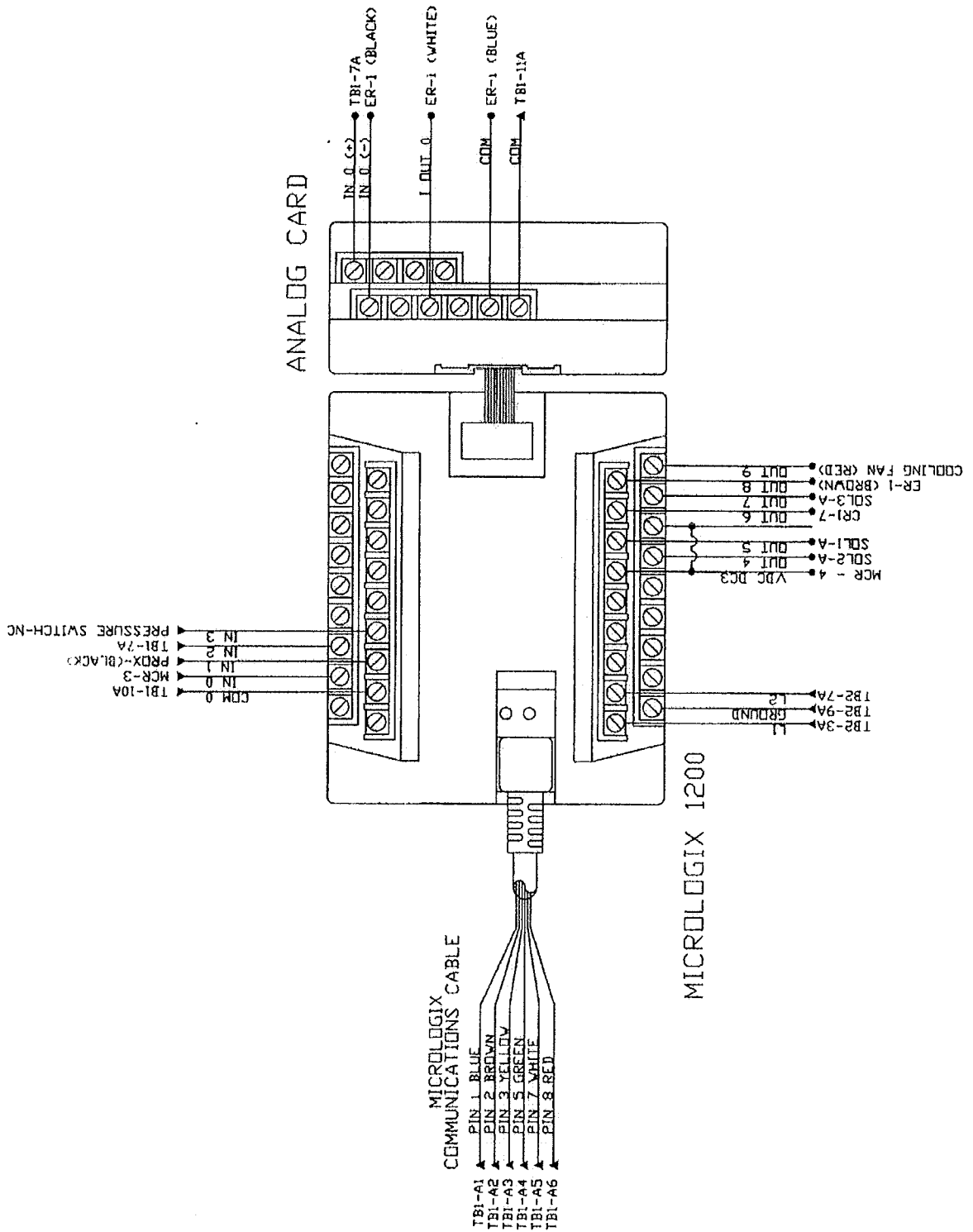



## 10.11 RELAYS 3DAT CONTROL MCR, CR1

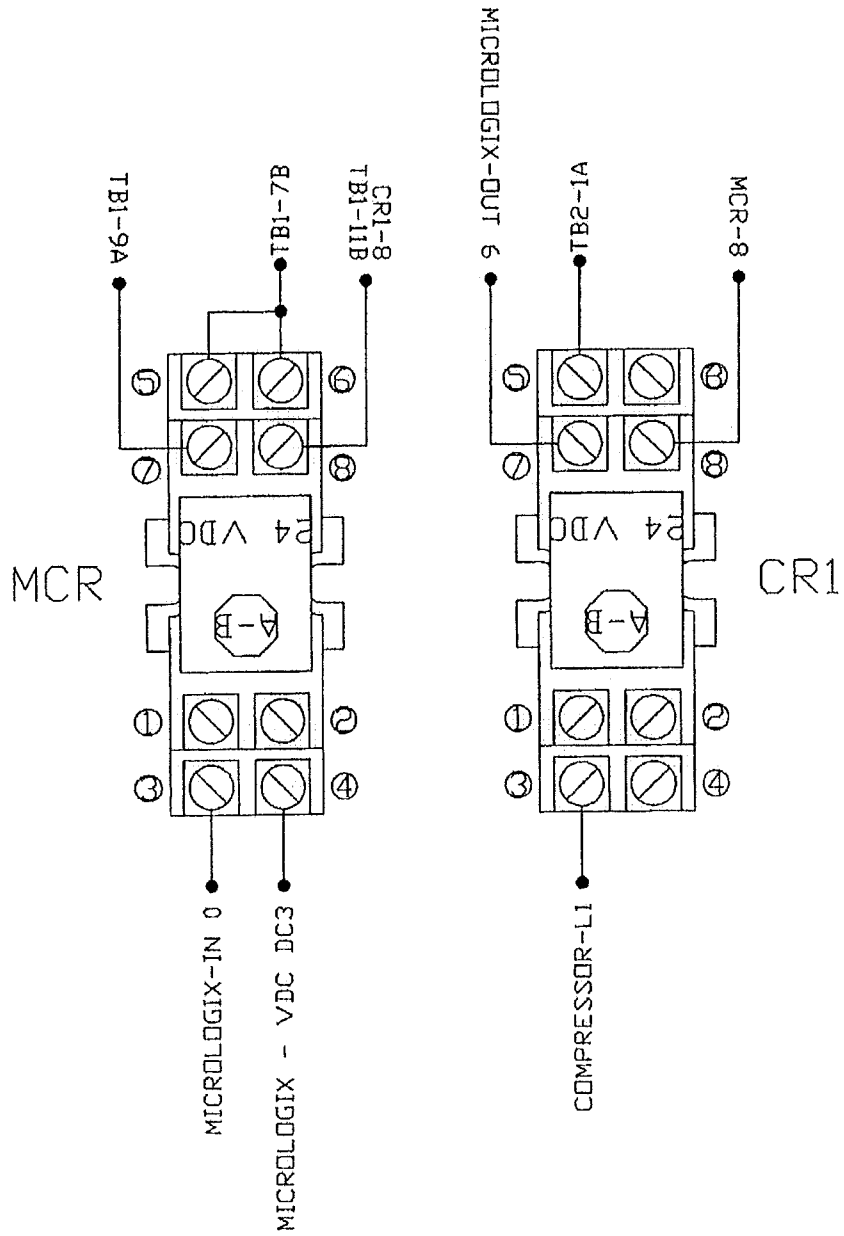



## 10.12 TERMINAL BLOCK ONE 3DAT

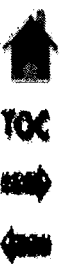
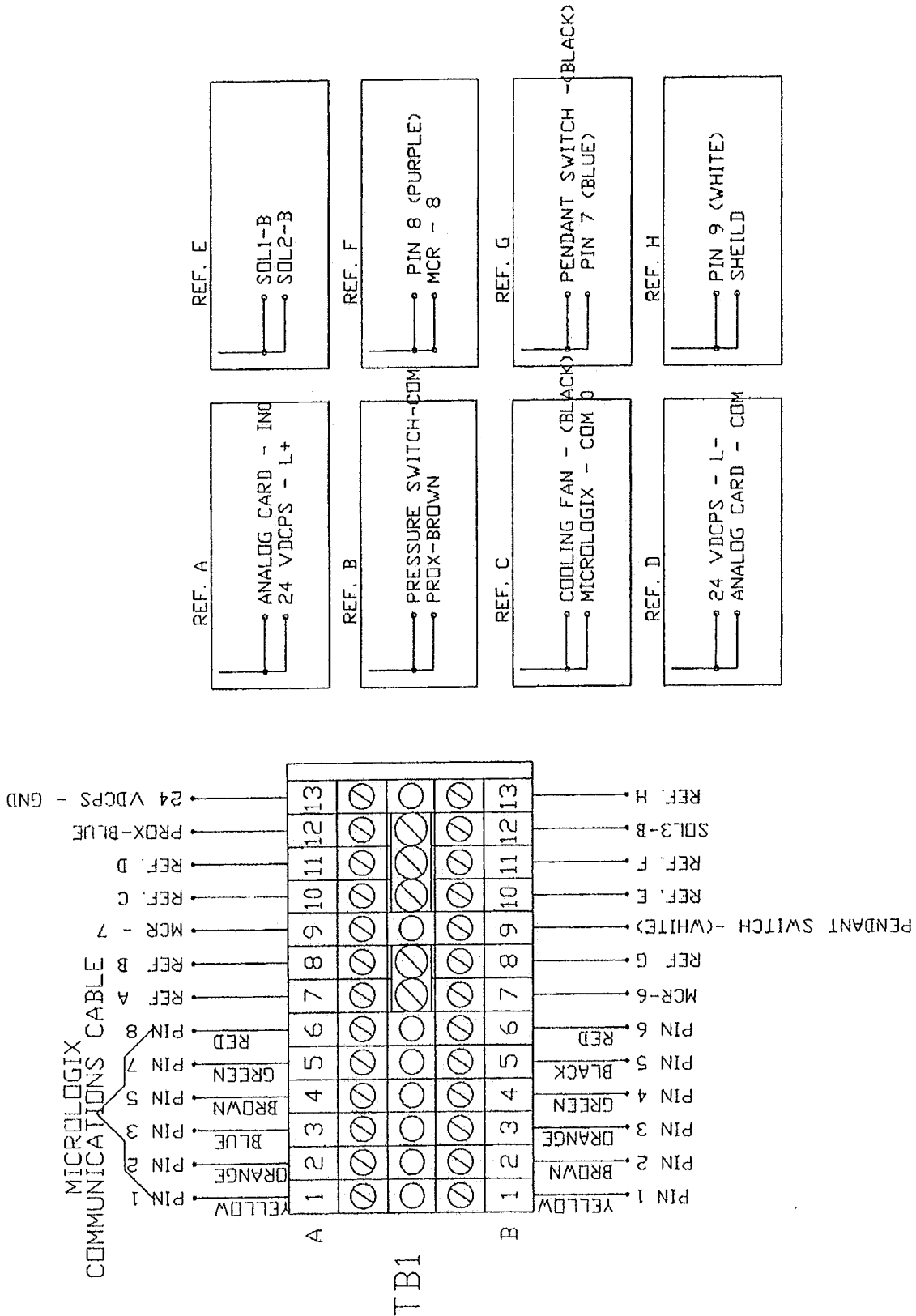



## 10.13 TERMINAL BLOCK ONE 3DAT

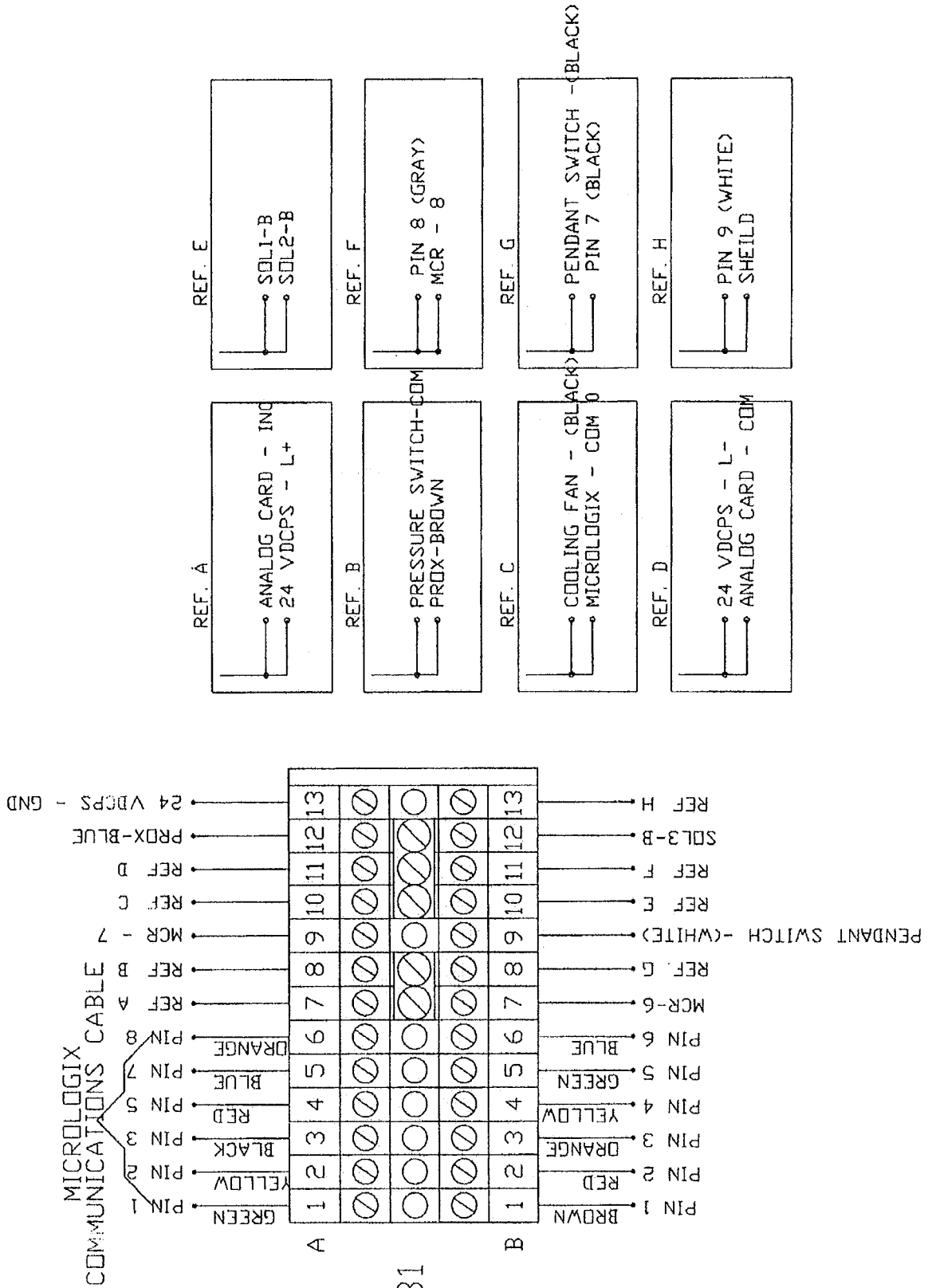





## 10.14 TERMINAL BLOCK ONE 3DAT

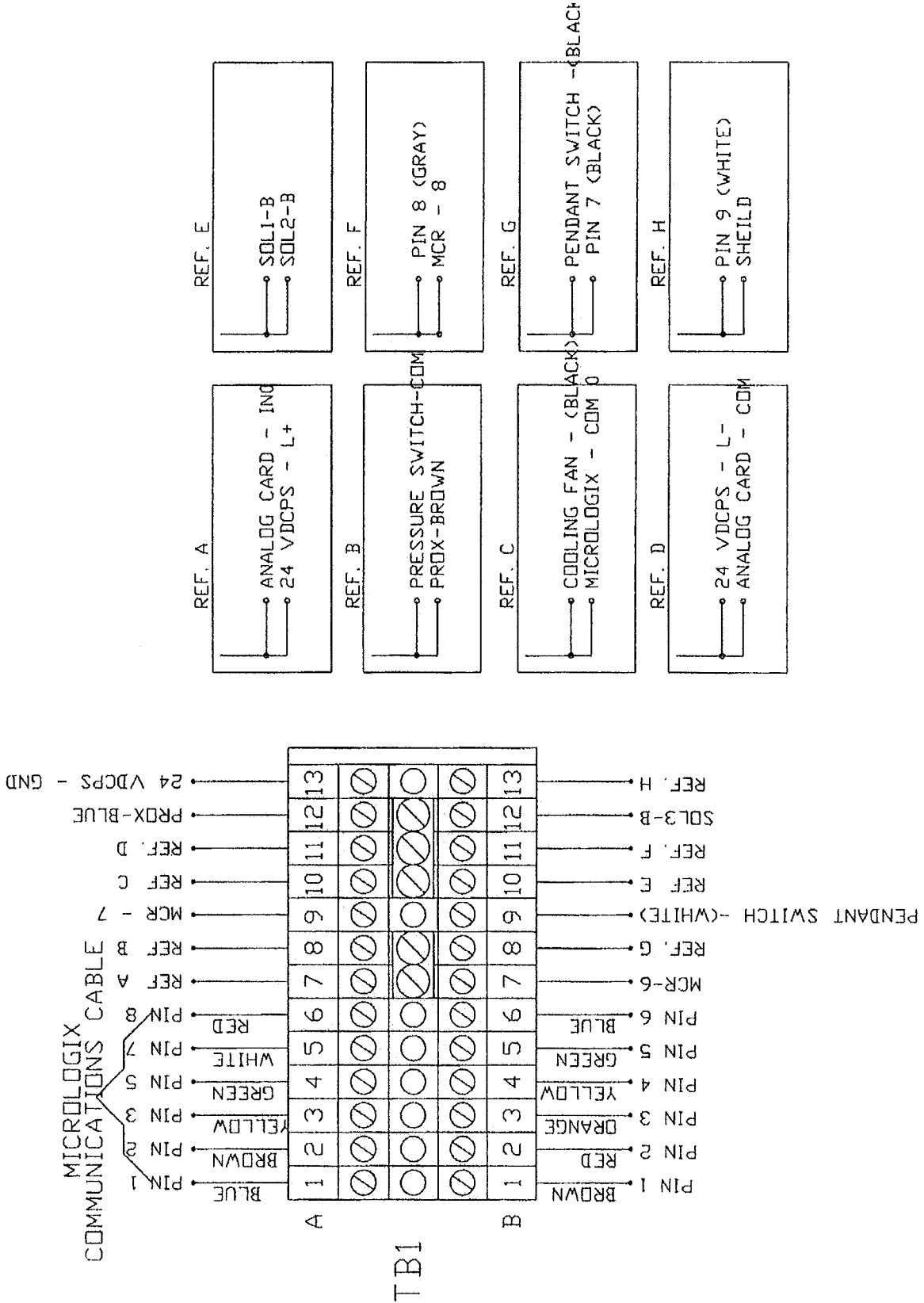



## 10.15 TERMINAL BLOCK ONE 3DAT 230

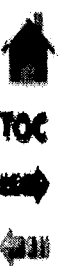
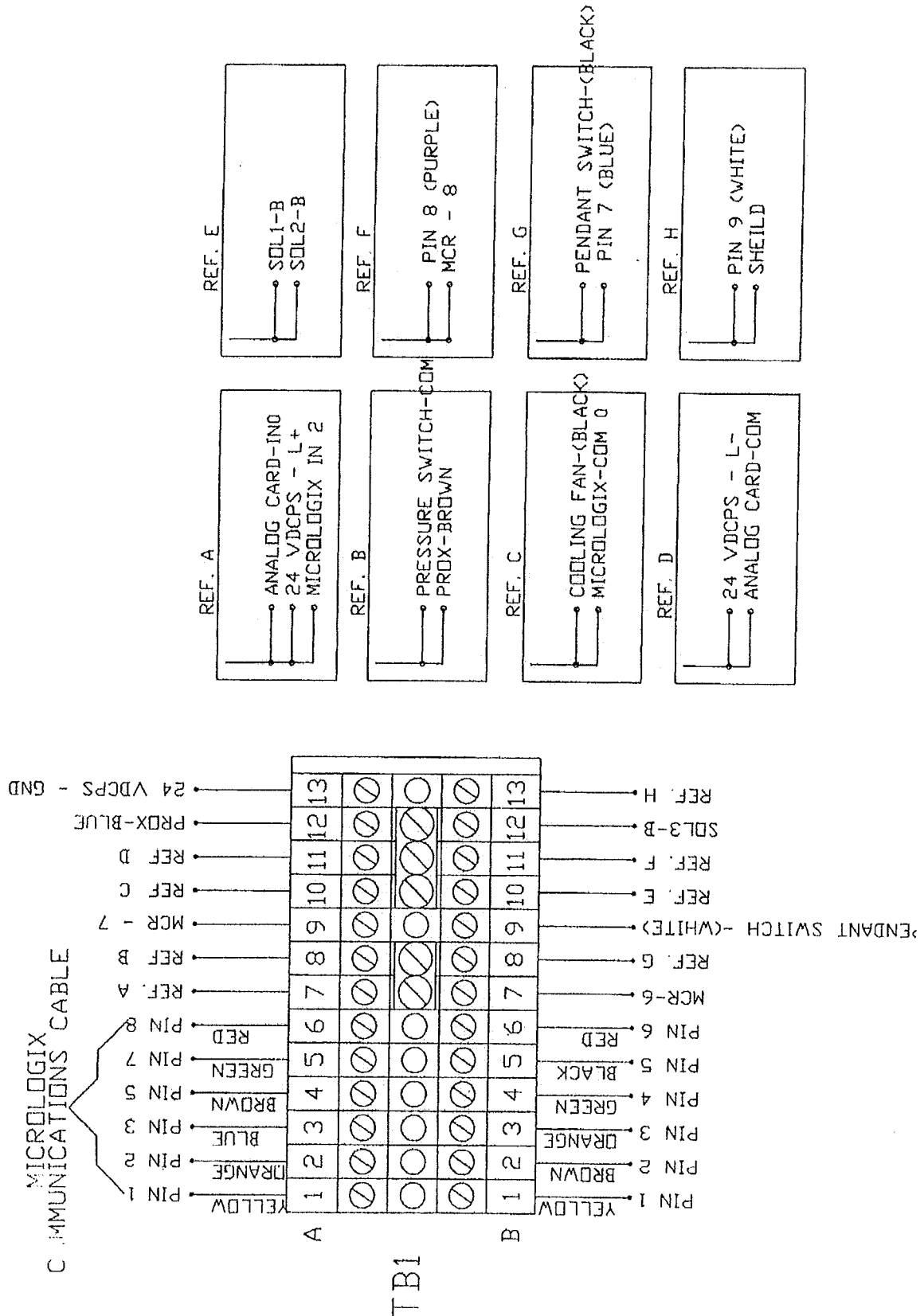

## 10.16 TERMINAL BLOCK ONE 3DAT 230

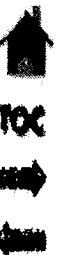
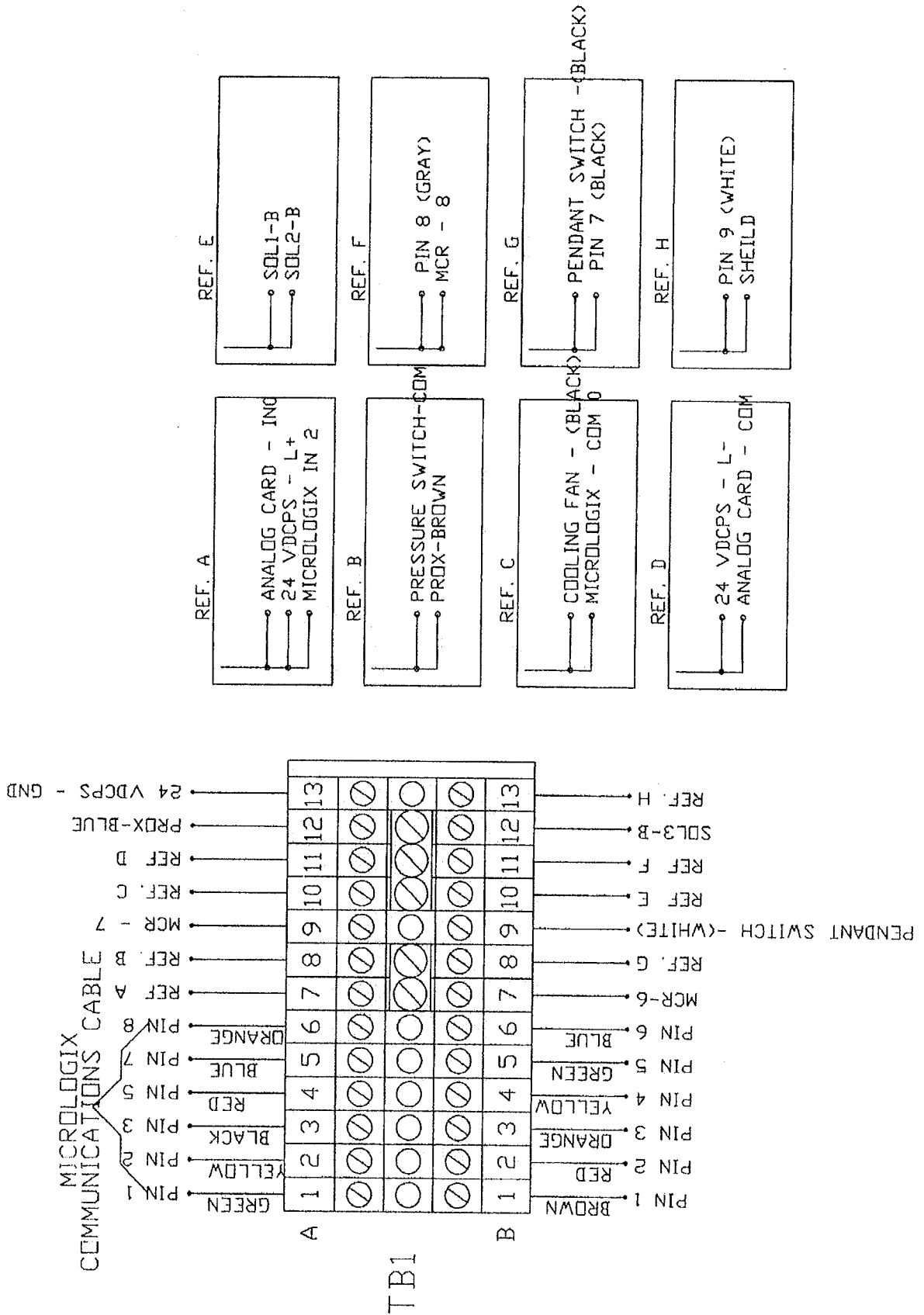



## 10.17 TERMINAL BLOCK ONE 3DAT 230

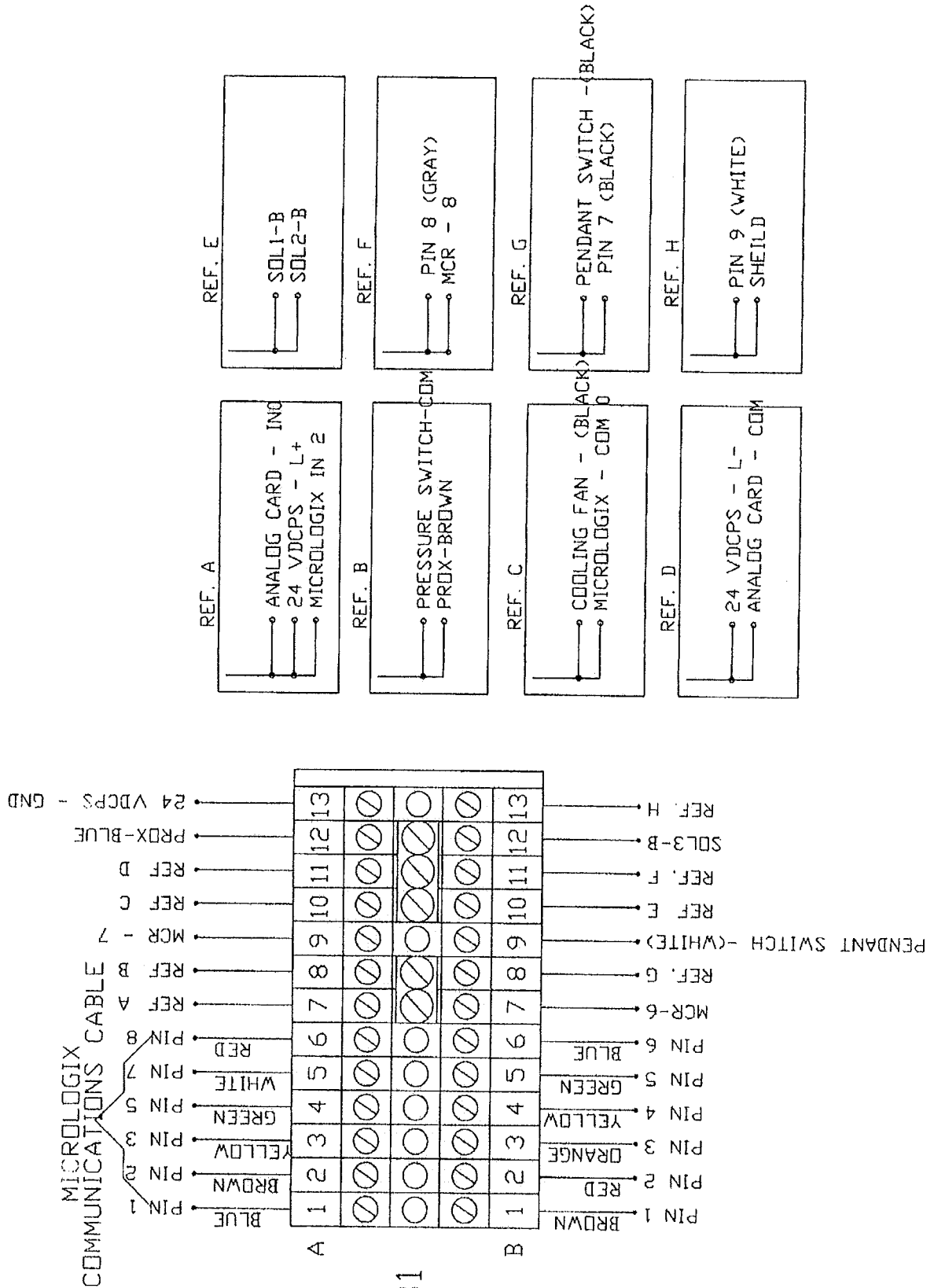



## 10.18 TERMINAL BLOCK TWO 3DAT

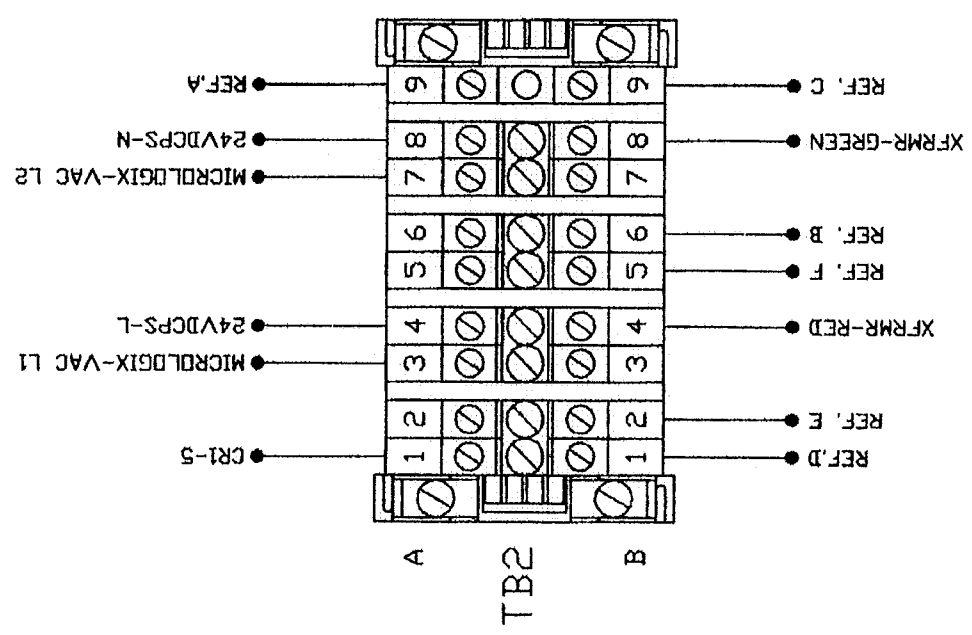
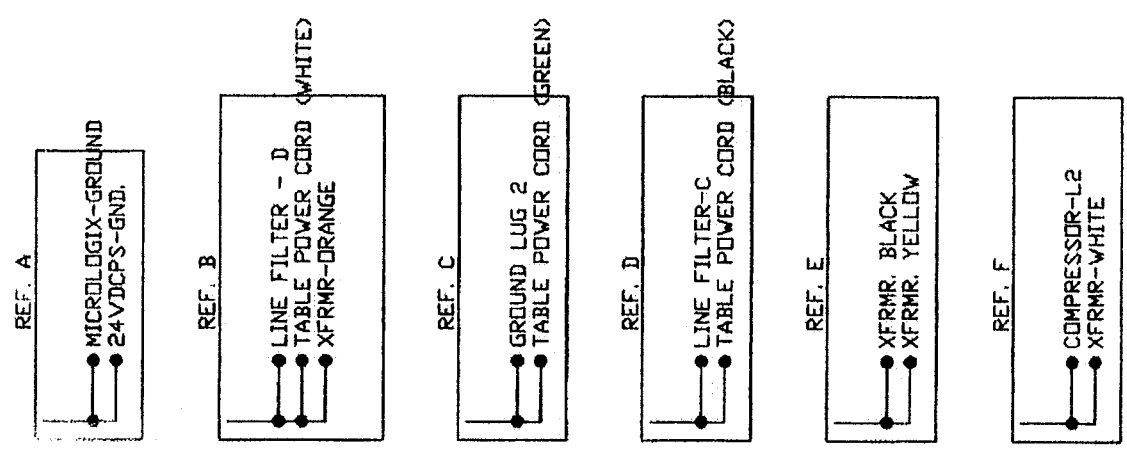



## 10.19 TERMINAL BLOCK TWO 3DAT 230

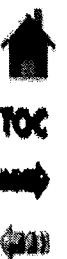
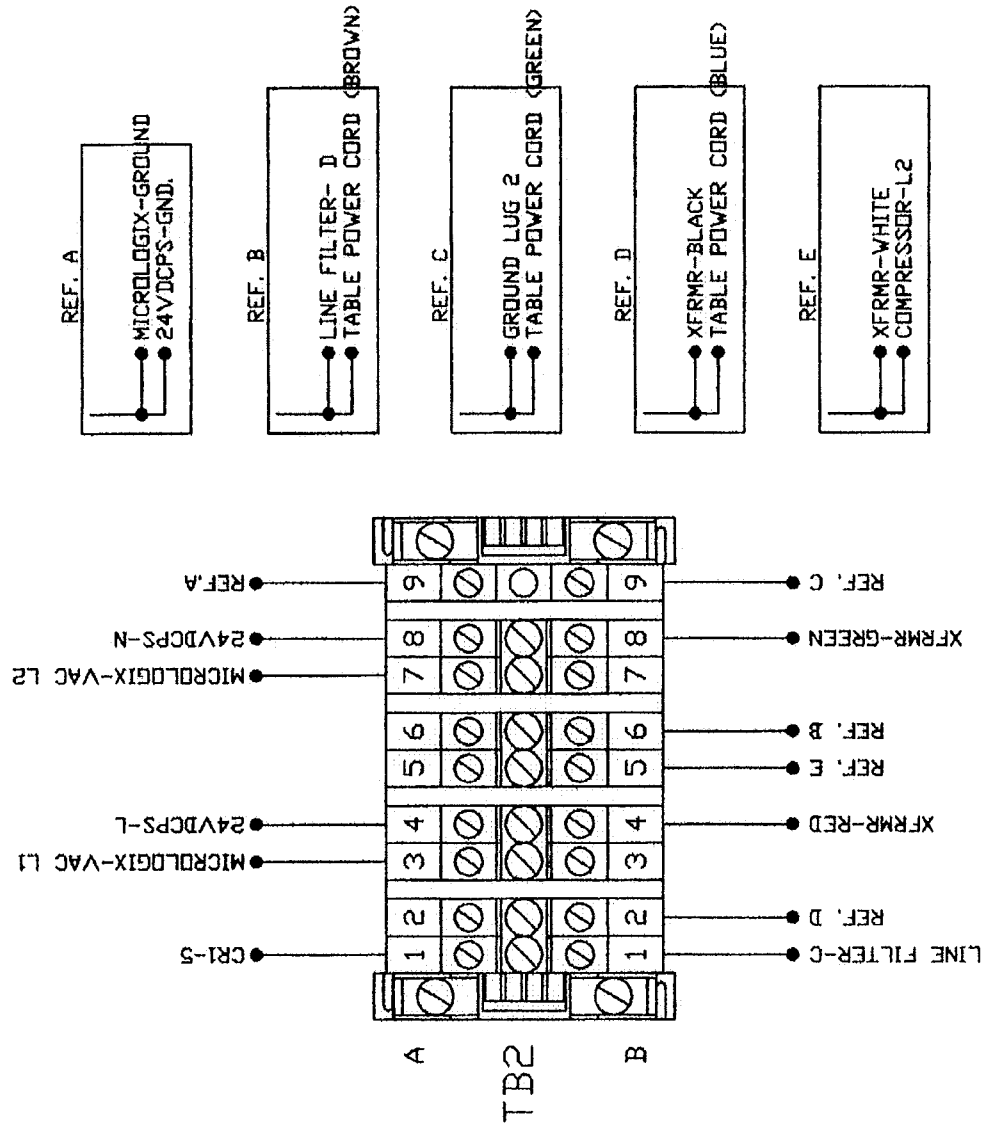



## 10.20 POWER SUPPLY 3DAT 24VDC

24 VDC  
POWER SUPPLY  
(24VDCPS)

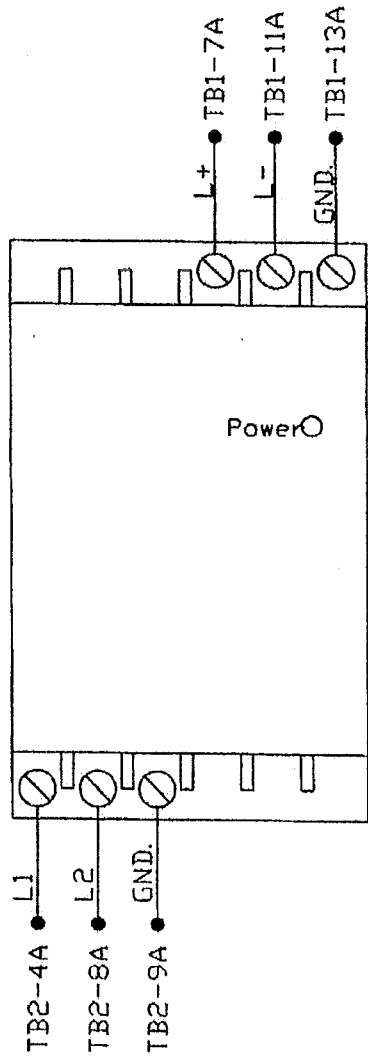



## 10.21 SOLENOID VALVES 3DAT

FILL  
SOLENOID  
(SOL 3)

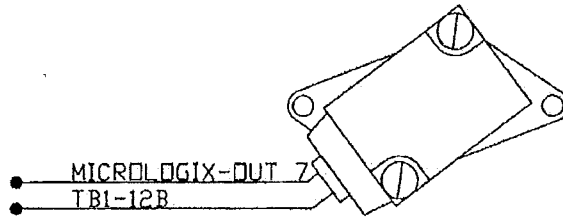

CERVICAL  
SOLENOID  
(SOL 2)

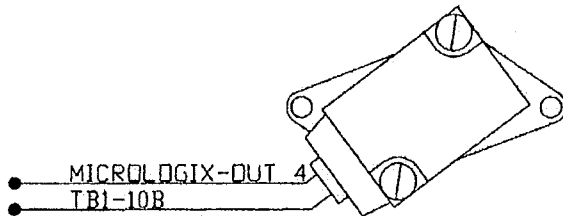

LUMBAR  
SOLENOID  
(SOL 1)

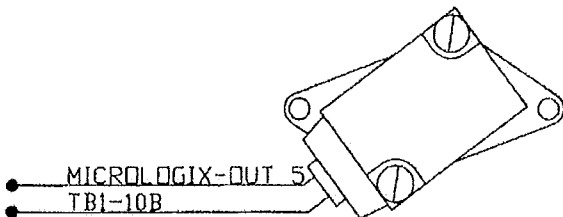

TOC







## 10.22 REGULATOR ELECTRONIC 3DAT

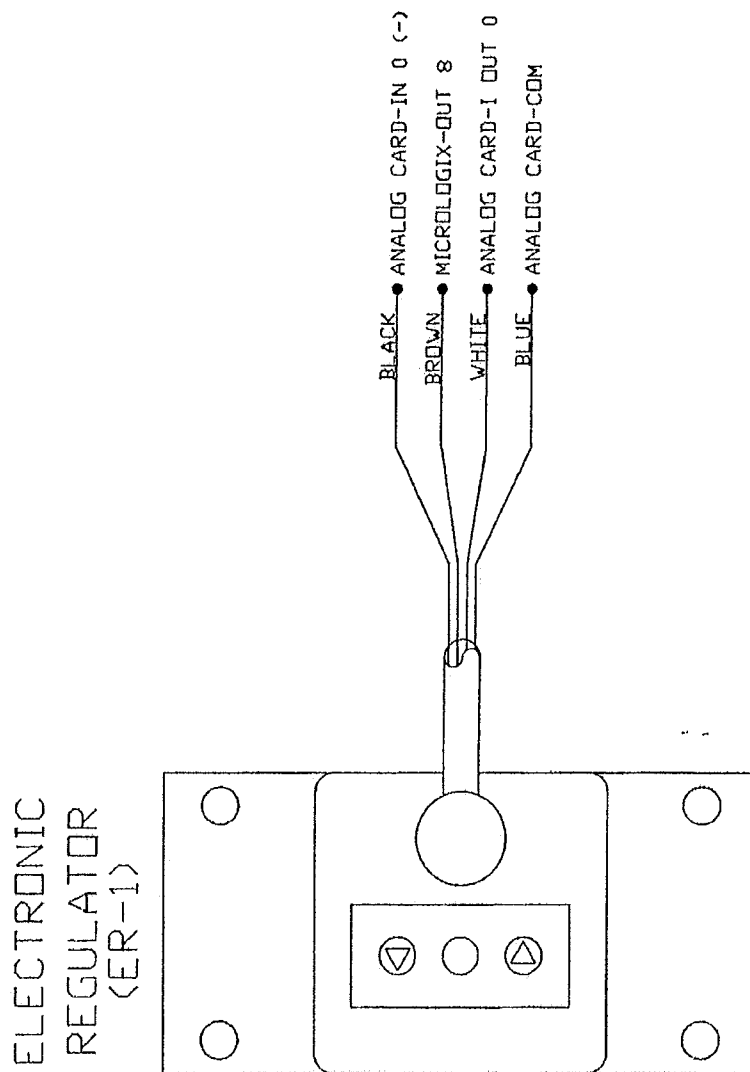



## 10.23 SWITCH PRESSURE PLATE

PRESSURE SWITCH

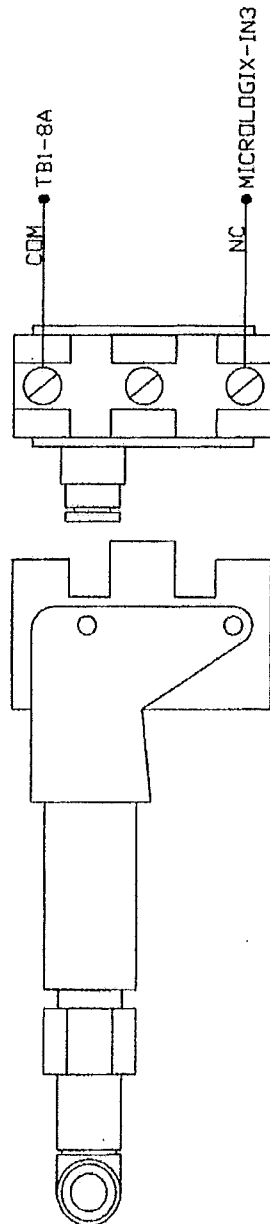

TOC





## 10.24 FAN 3DAT COOLING

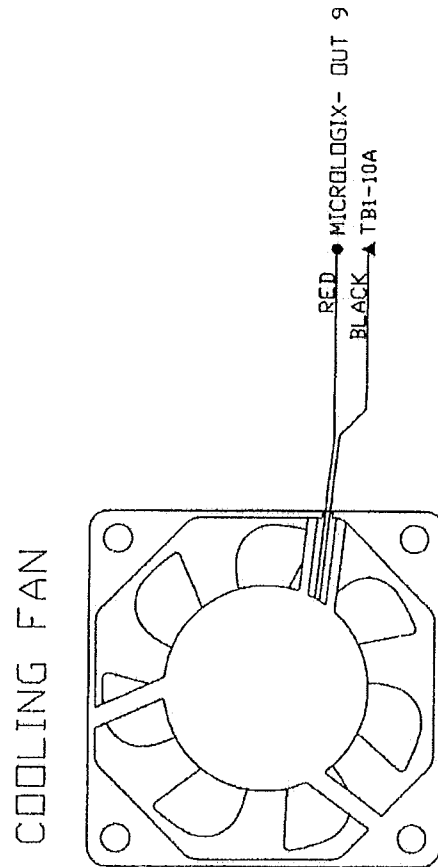

TOC





## 10.25 CABLE 3DAT POWER

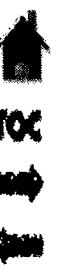
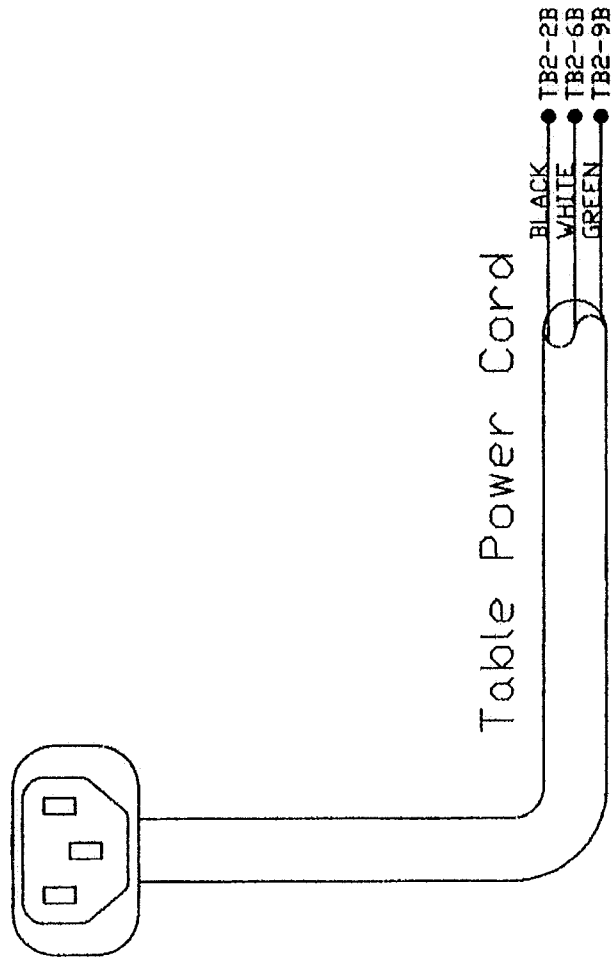



## 10.26 CABLE 3DAT POWER 230

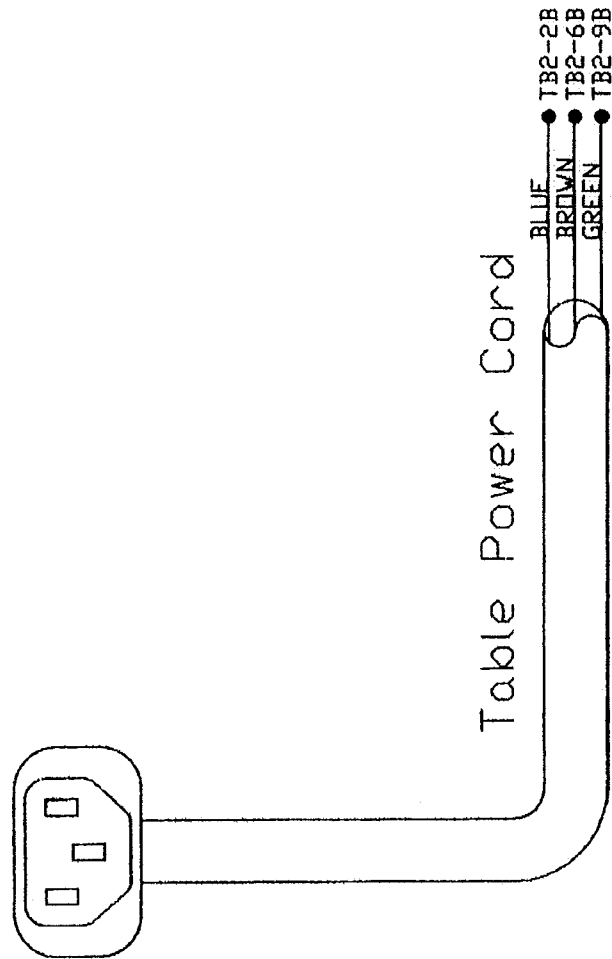



## 10.27 SWITCH 3DAT PROXIMITY

PROXIMITY SWITCH

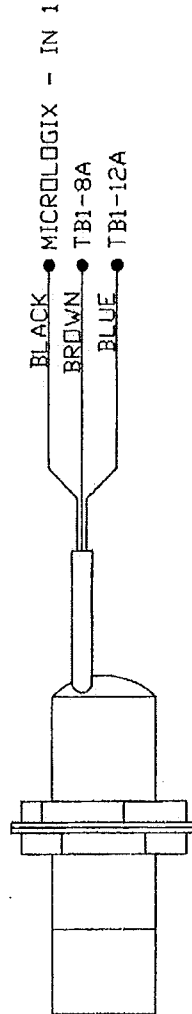

TOC





## 10.28 SWITCH 3DAT PATIENT CONTROL

PATIENT SWITCH

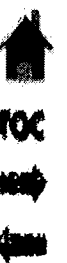
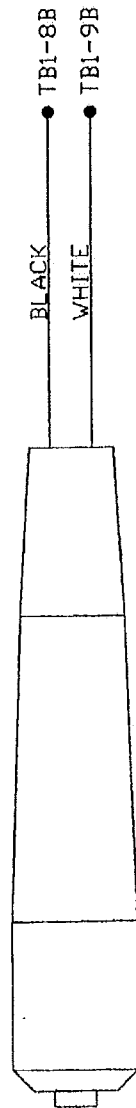



## 10.29 COMPRESSOR PUMP 3DAT 120V

COMPRESSOR

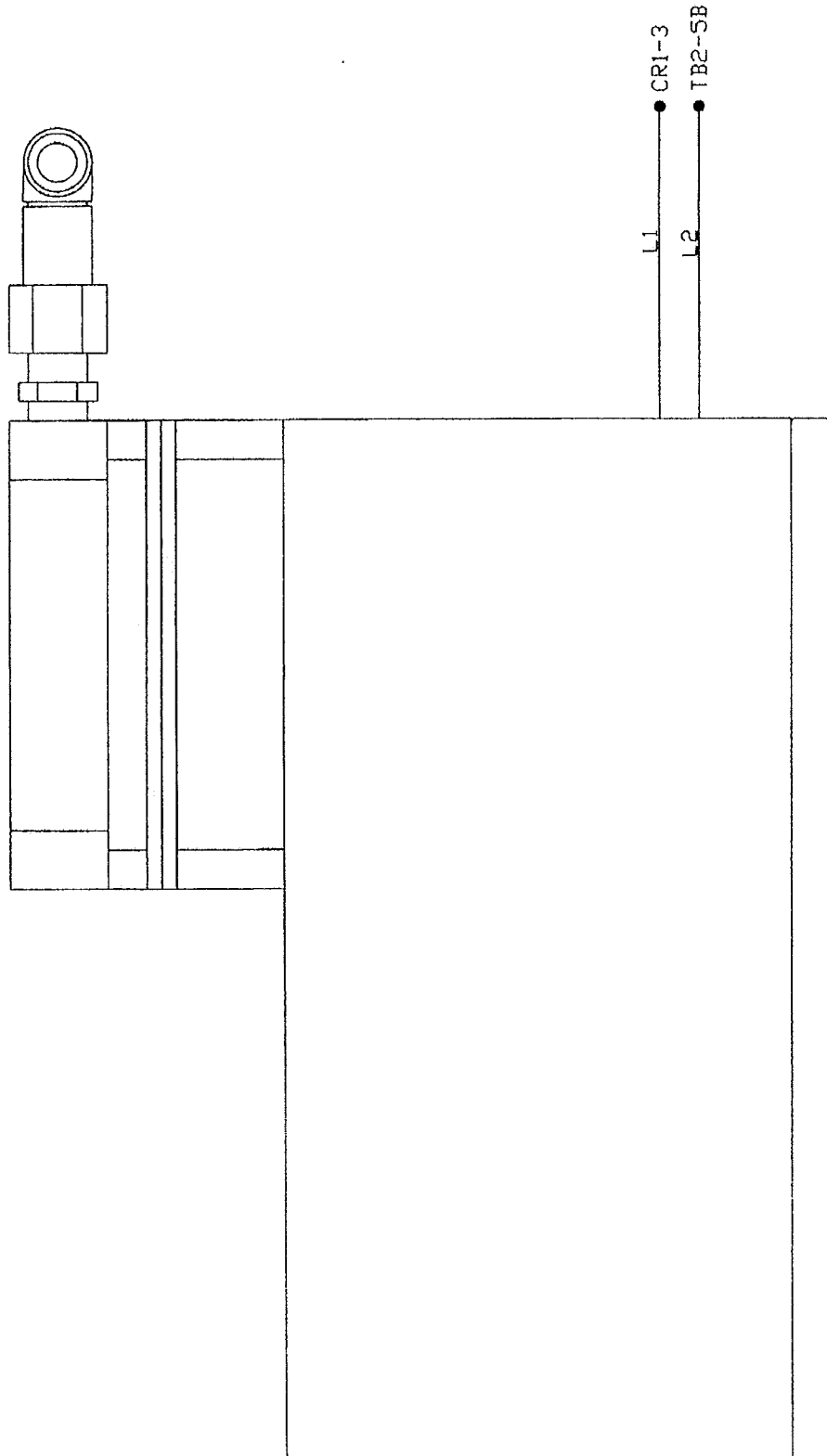

TOC







10.30 COMPRESSOR PUMP 3DAT 230V

COMPRESSOR

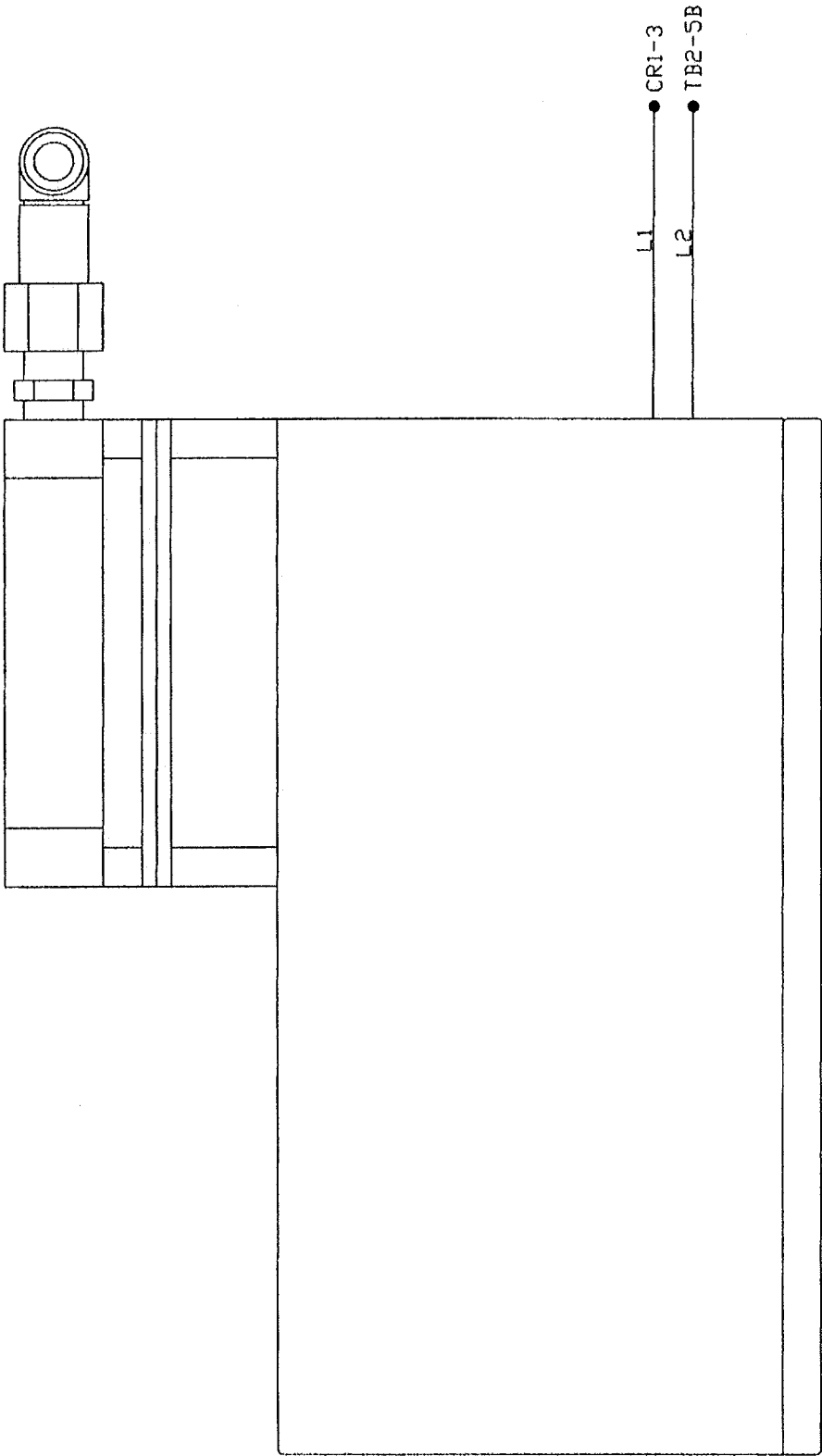



## 10.31 SWITCH 3DAT MASTER

### MASTER SWITCH

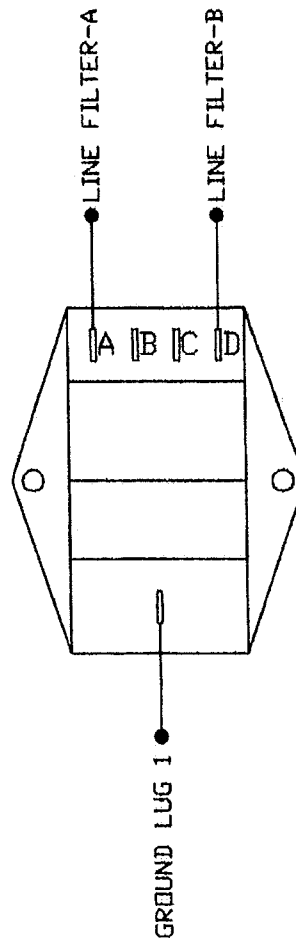

10.32 SWITCH 3DAT MASTER 230

MASTER SWITCH

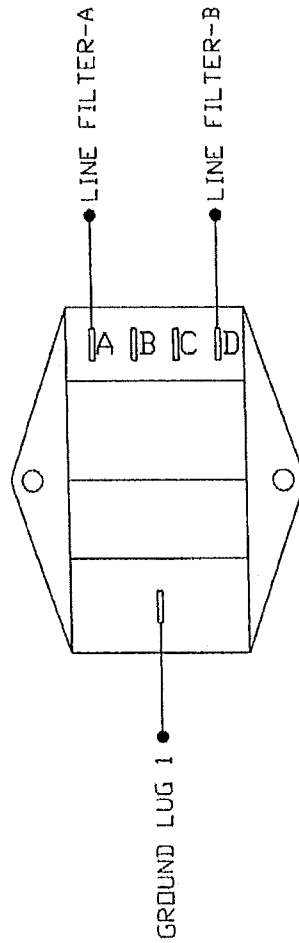



## 10.33 TERMINAL 3DAT PANEL VIEW

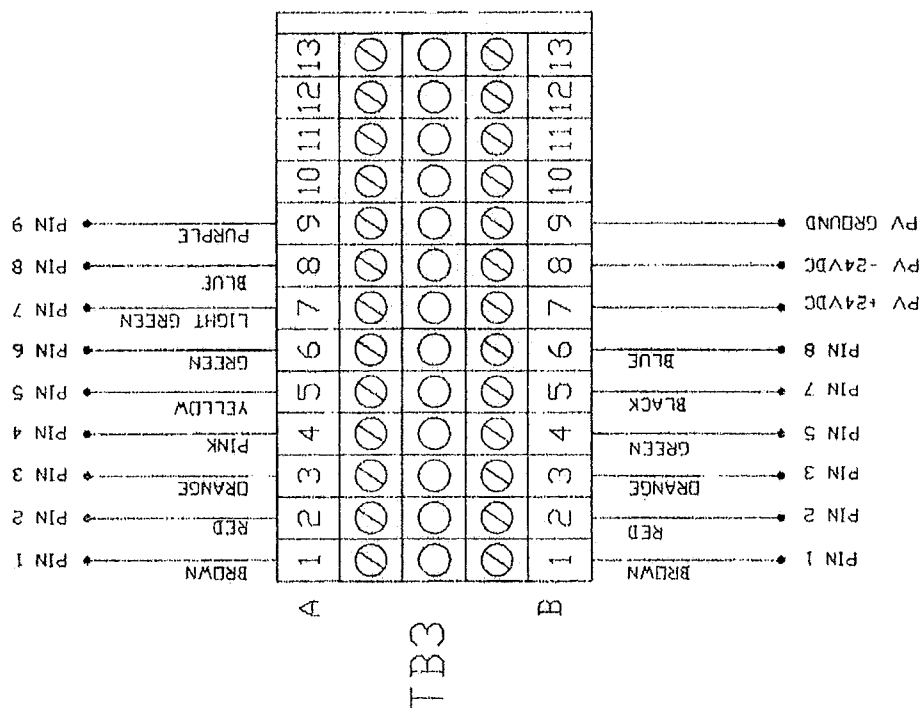

PANEL VIEW  
TERMINALS





## 10.34 TERMINALS 3DAT PANEL VIEW

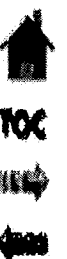
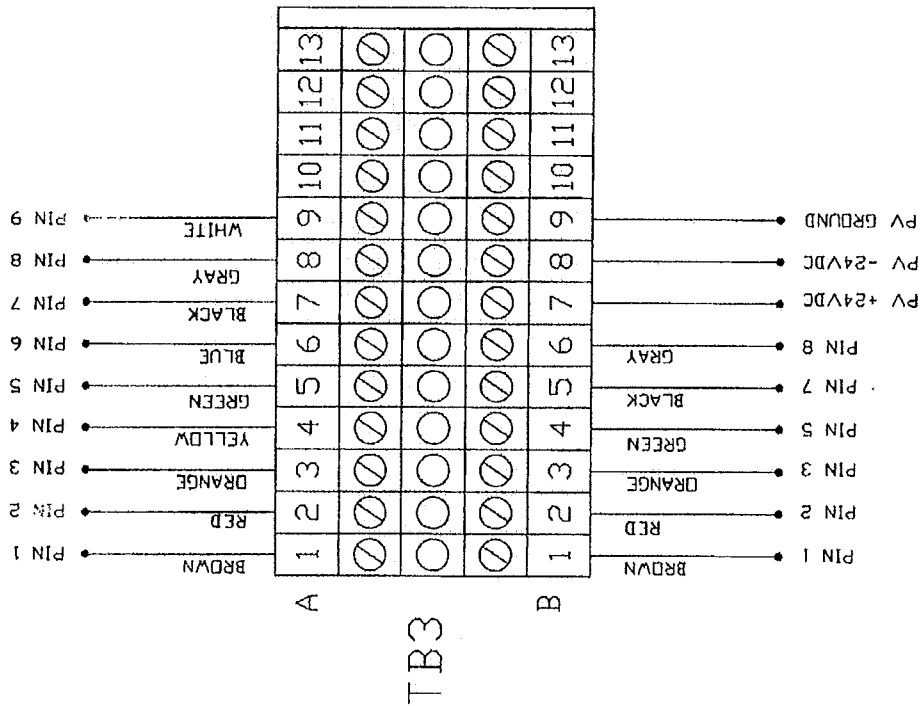



## 10.35 TERMINAL 3DAT PANEL VIEW

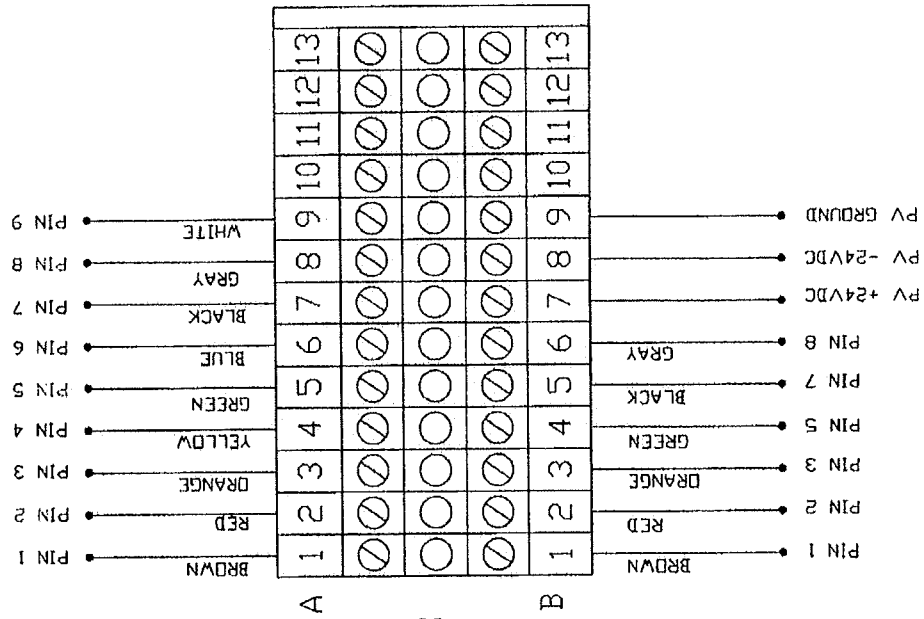

PANEL VIEW  
TERMINALS

TB3





## 10.36 TRANSFORMER 3DAT 120 TOROID

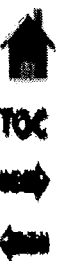
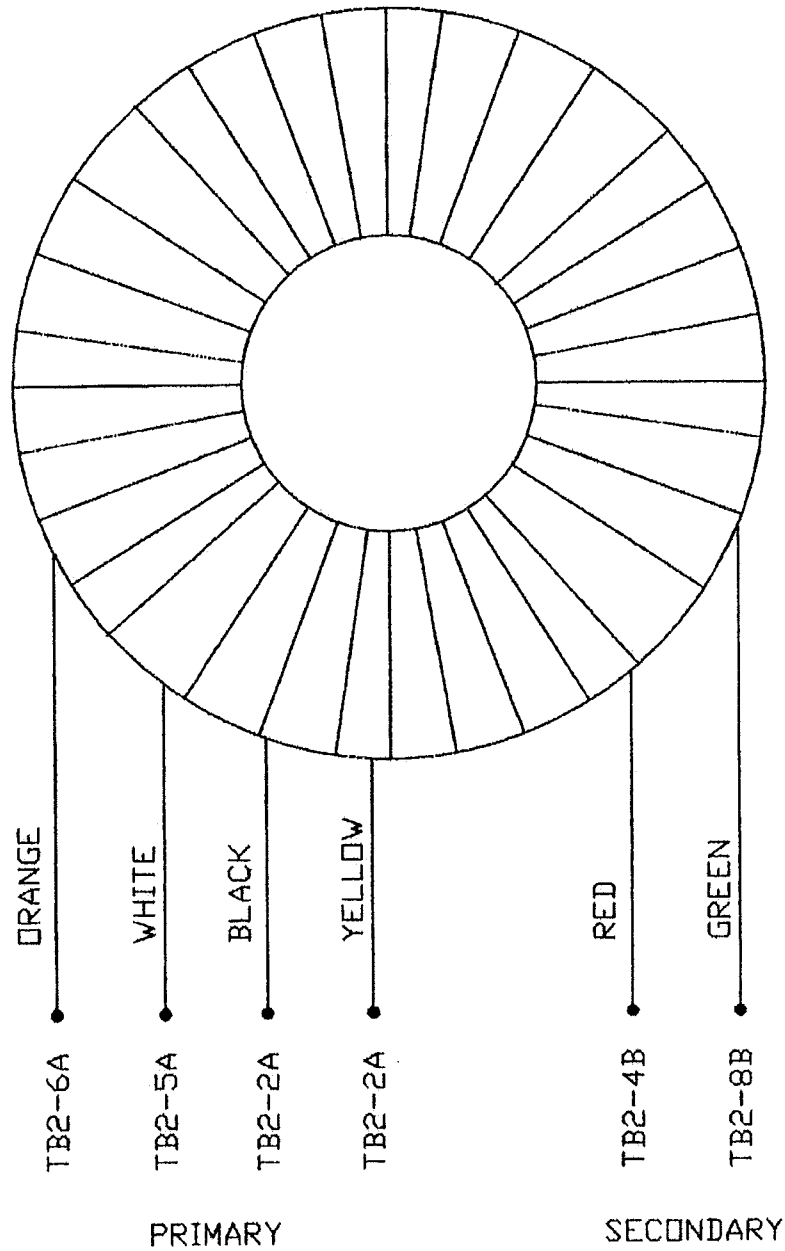



## 10.37 TRANSFORMER 3DAT 230 TOROID

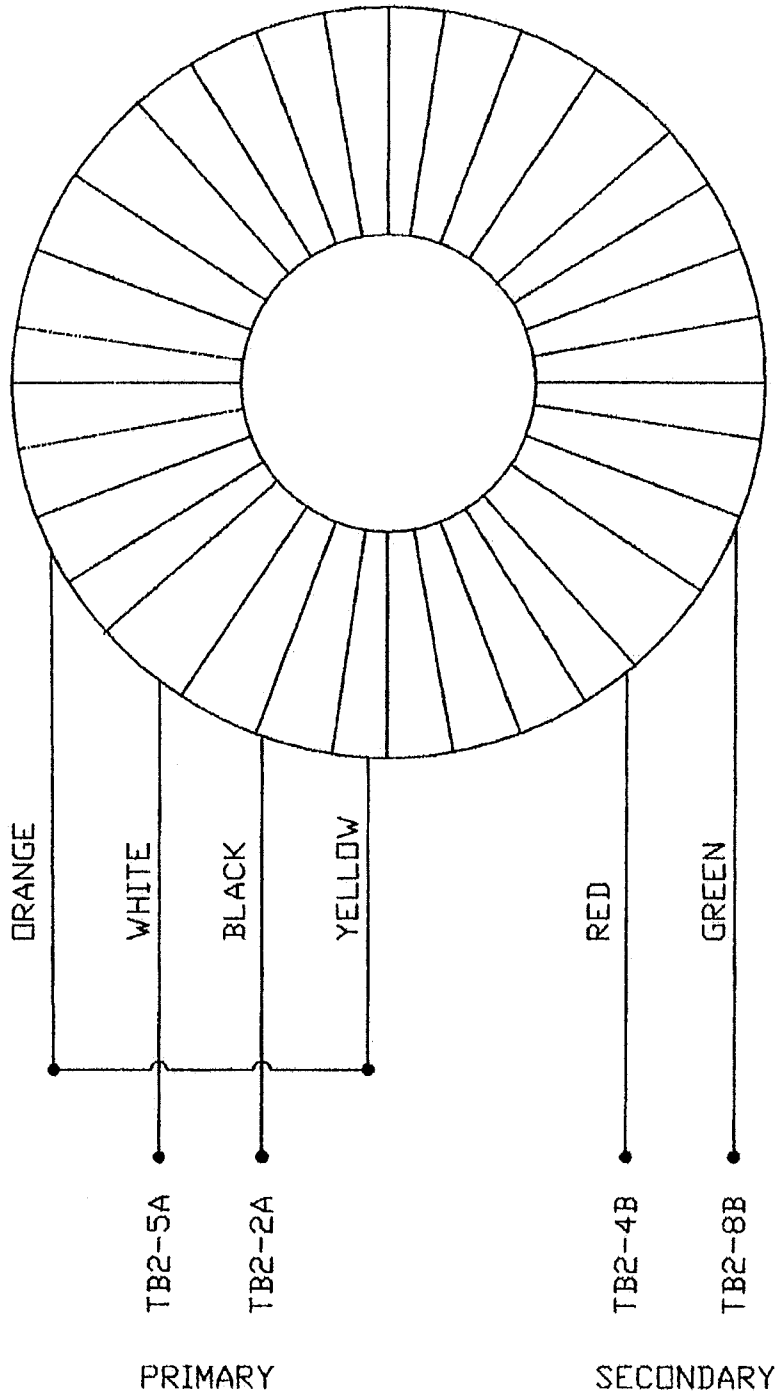





## 10.38 FILTER LINE 3DAT 230

### LINE FILTER

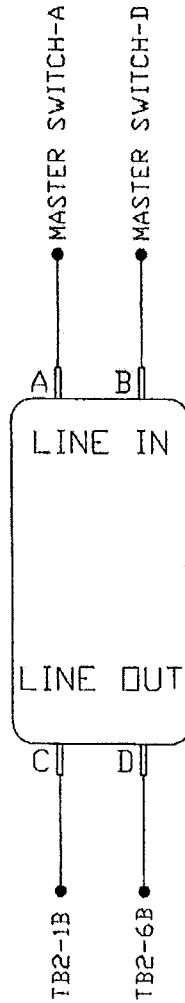

TOC





## 10.39 DIAGRAM 3DAT PNEUMATIC

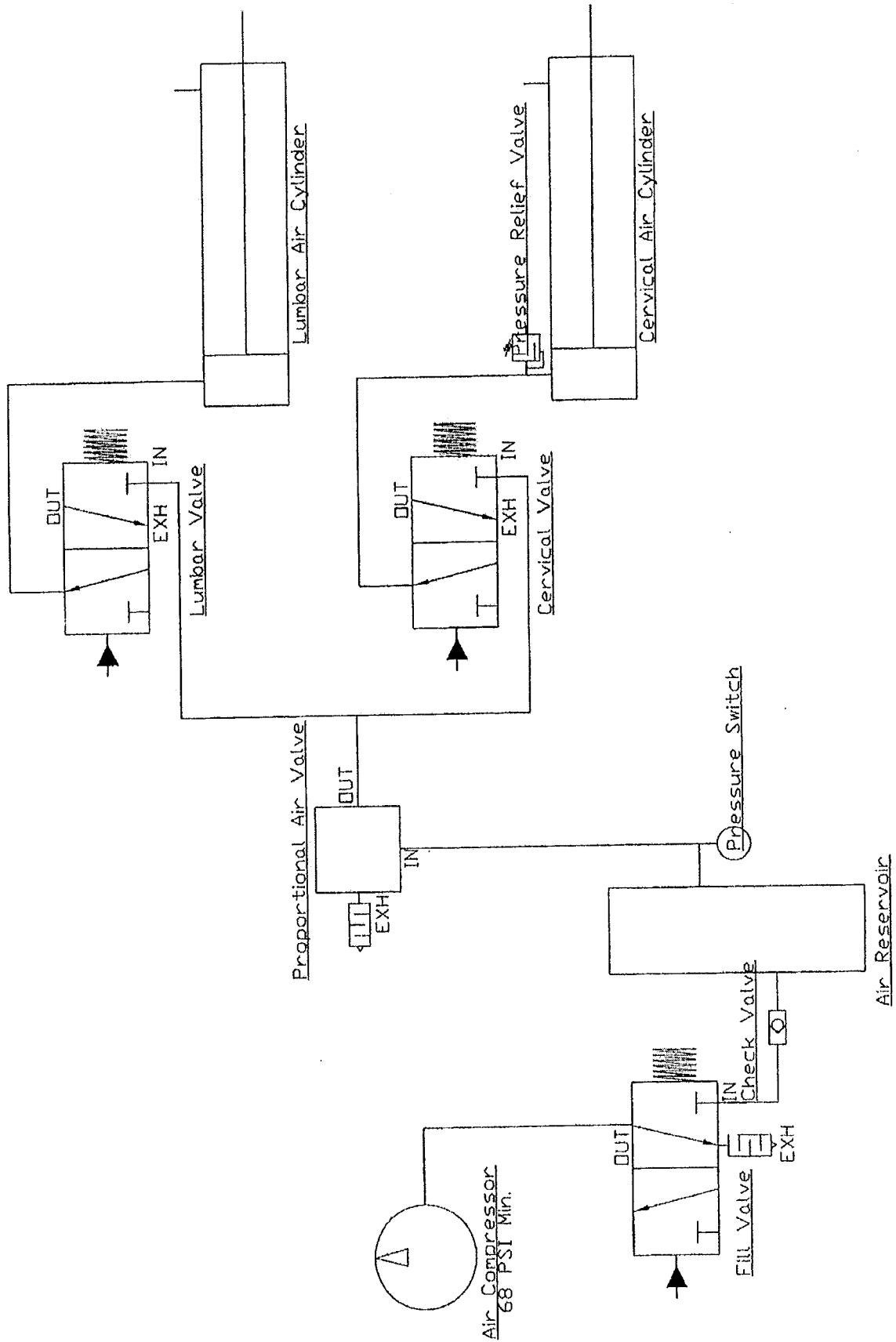



## 10.40 SCHEMATICS WIRING 3DAT

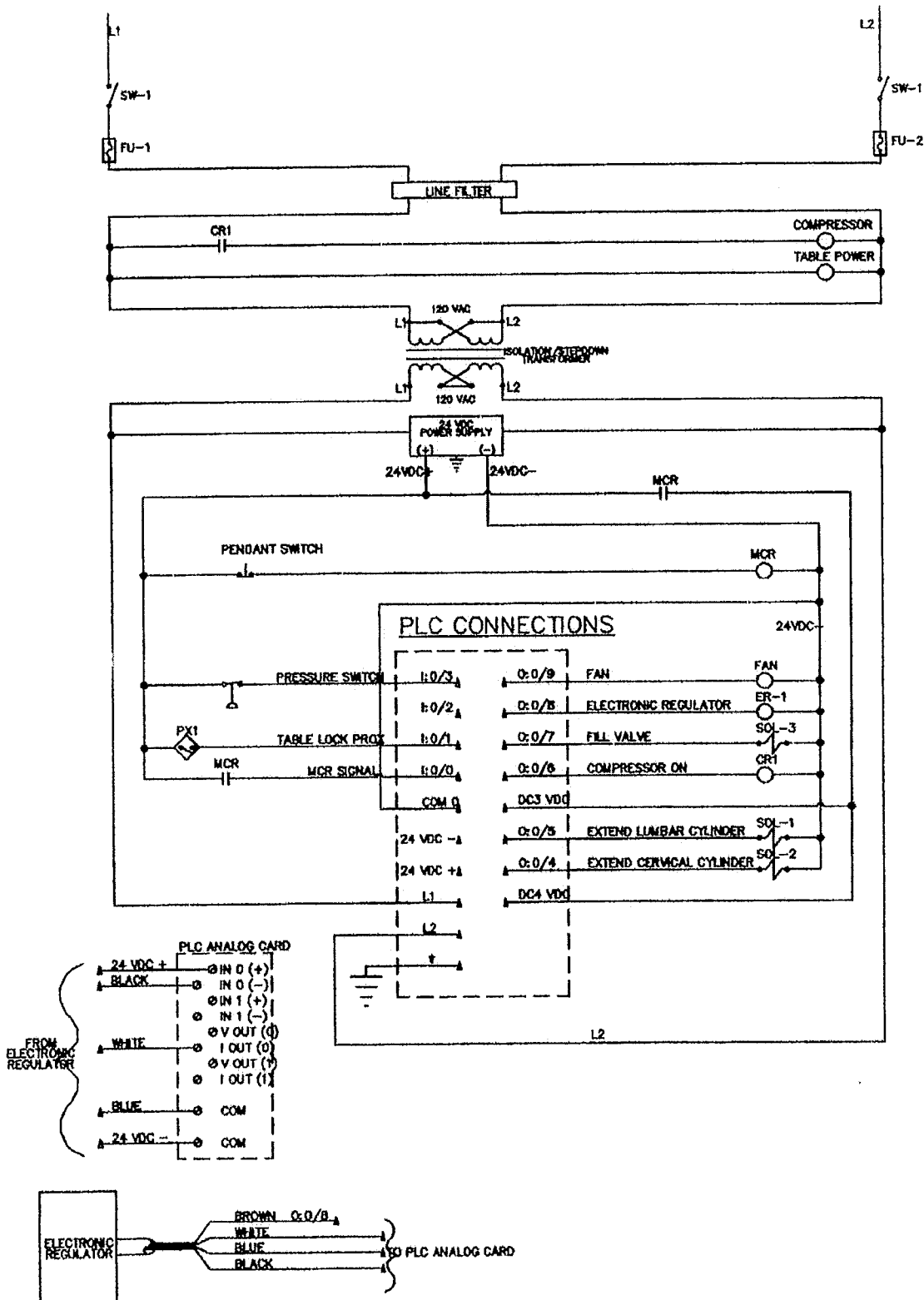



## 10.41 SCHEMATICS WIRING 3DAT 230V

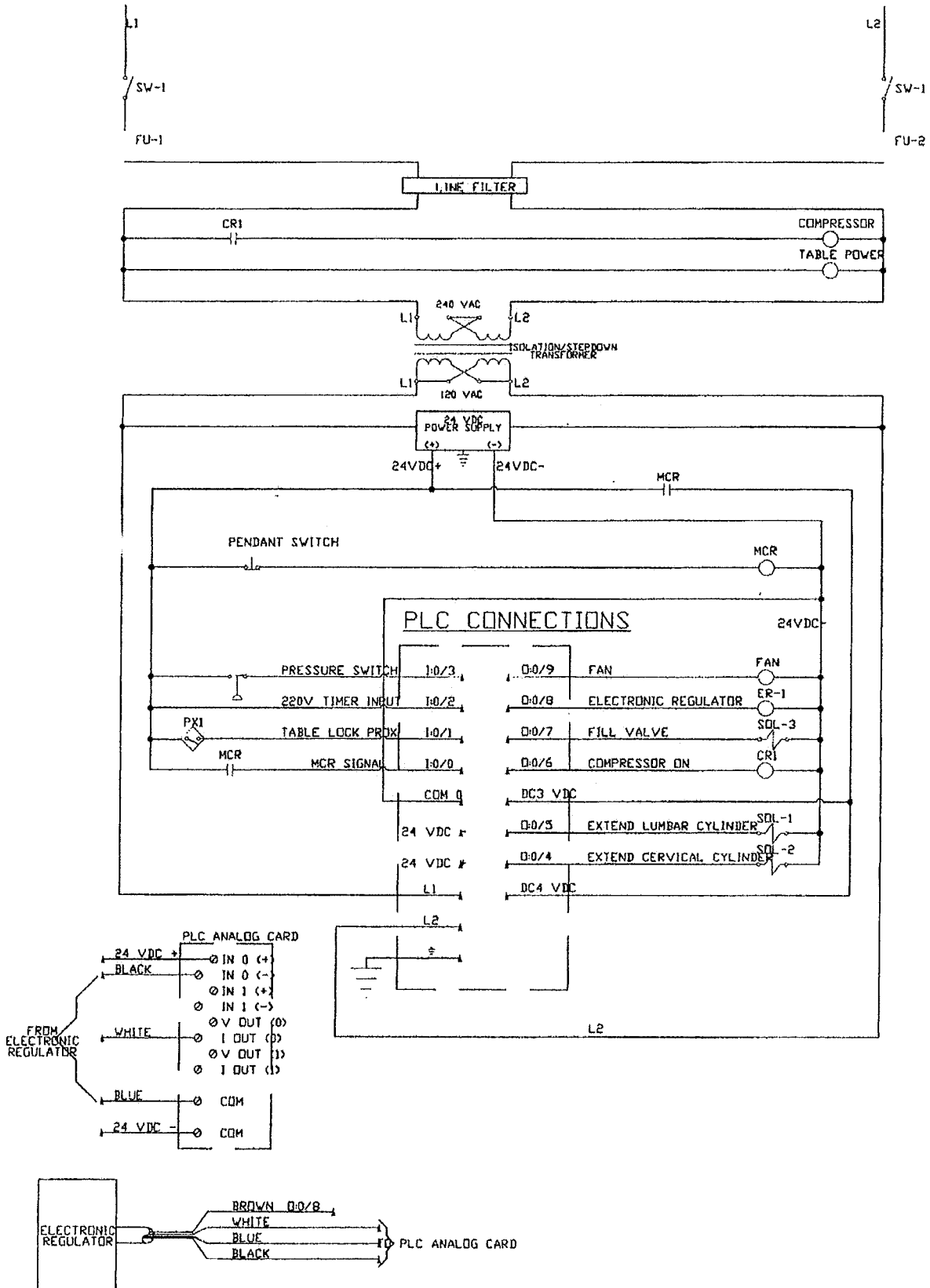



Chattanooga Group, a division of Encore Medical, L.P., ("Company") warrants that the 3D ActiveTrac ("Product") is free of defects in material and workmanship. This warranty shall remain in effect for one year (12 months) from the date of original consumer purchase. If this Product fails to function during the one year warranty period due to a defect in material or workmanship, at the Company's option, the Company or the selling dealer will repair or replace this Product without charge within a period of thirty days from the date on which the Product is returned to the Company or the dealer.

All repairs to the Product must be performed by a service center certified by the Company. Any modifications or repairs performed by unauthorized centers or groups will void this warranty.

The warranty period for accessories is 90 days.

To participate in warranty coverage, this Product's warranty registration card (included with Product) must be filled out and returned to the Company by the original owner within ten business days of purchase.

### **This Warranty Does Not Cover:**

- Replacement parts or labor furnished by anyone other than the Company, the selling dealer, or a certified Company service agent.
- Defects or damage caused by labor furnished by someone other than Company, the selling dealer, or a certified Company service agent.
- Any malfunction or failure in the Product caused by product misuse, including, but not limited to, the failure to provide reasonable and necessary maintenance or any use that is inconsistent with the Product User Manual.

### **COMPANY SHALL NOT BE LIABLE IN ANY EVENT FOR INCIDENTAL OR CONSEQUENTIAL DAMAGES.**

Some states do not allow the exclusion or limitation of incidental or consequential damages, so the above limitation or exclusion may not apply to you.

To obtain service from Company or the selling dealer under this warranty:

1. A written claim must be made within the warranty period to the Company or the selling dealer. Written claims made to the Company should be sent to:

4717 Adams Road  
P.O. Box 489  
Hixson, TN 37343 USA  
1-423-870-2281  
1-800-592-7329 U.S.A.  
1-423-875-5497 U.S.A. FAX  
1-800-266-0026 SERVICE PHONE  
chattgroup.com

2. The Product must be returned to the Company or the selling dealer by the owner.

This warranty gives you specific legal rights and you may also have other rights which vary from state to state or location to location.

The Company does not authorize any person or representative to create for it any other obligation or liability in connection with the sale of the Product. Any representation or agreement not contained in the warranty shall be void and of no effect.

**THE FOREGOING WARRANTY IS IN LIEU OF ALL OTHER WARRANTIES, EXPRESSED OR IMPLIED, INCLUDING ANY WARRANTY OR MERCHANTABILITY OR FITNESS FOR A PARTICULAR PURPOSE.**



Moving  
Rehabilitation  
Forward™



ISO 13485 Certified

4717 Adams Road  
P.O. Box 489  
Hixson, TN 37343 U.S.A.  
1-423-870-2281  
1-800-592-7329 U.S.A.  
1-423-875-5497 U.S.A. FAX  
1-800-266-0026 SERVICE PHONE  
chattgroup.com



TOC

